



Model HQ-1103



Doc: HQ/1103/01
Nov 2009

IP67 Electrically operated 2 way brass ball valve

Full bore 2 way nickel plated brass ball valve, designed for automation with integrally cast ISO5211 actuator mounting platform fitted with direct mounted HQ-04 electric actuator. Supplied assembled and dry bench function tested.

Size range from 1/2" to 2".

Valves are WRAS approved for use on potable water.

Type	Power supply & function
HQ-1103-240	220/1ph/50Hz (or 60Hz) On-off
HQ-1103-110	110/1ph/50Hz (or 60Hz) On-off
HQ-1103-24AC	24/1ph/50Hz (or 60Hz) On-off
HQ-1103-24VDC	24VDC On-off



For failsafe or modulating applications see the Type: J3-1100

Applications:

Water, oil and most non-corrosive media, subject to compatibility with wetted parts in contact with media. Actuators sized on a maximum differential pressure of 10 bar wet service, if the intended duty is above this differential, or dry (air or gas) call to check actuator sizing as a larger output actuator may be required.

NOT recommended for use on steam.

Maximum working temperature of assembly is +70C. If the intended duty is a higher temperature than this, select model HQ-1113 which has a mounting kit between the valve and actuator which uses air cooling to dissipate the heat away from the actuator (maximum +130C).

Valve Specifications:

Body	Nickel plated brass
Ball	Nickel plated brass
Seats	PTFE
Pressure rating	UTI 2" 40 bar
Valve temp limits	-20 to +150°C
Actuator temp limits	-20 to + 70°C



Quick guide to the HQ-04 electric actuator standard features :

IP67 Weatherproof housing.
(Can be submerged for a maximum of 30 minutes under a maximum of 1m of water.)

Torque output Max 40Nm

Available supply voltages:

220V AC / 1ph

110V AC / 1ph

24V AC / 1ph

24V DC

Anti-condensation heater

Manual override facility

2 End of travel SPDT switches

2 x M20 Conduit cable entries

Terminal strip inside

-20 to +70C Ambient temperature range

Duty cycle S2 = 35%

Working time 14 secs (50 Hz)

Weight 3kgs

Dry powder polyester coated aluminium housing.

Serial numbered





Model HQ-I 103

WIRING DIAGRAMS



Doc: HQ/I 103/01

Nov 2009

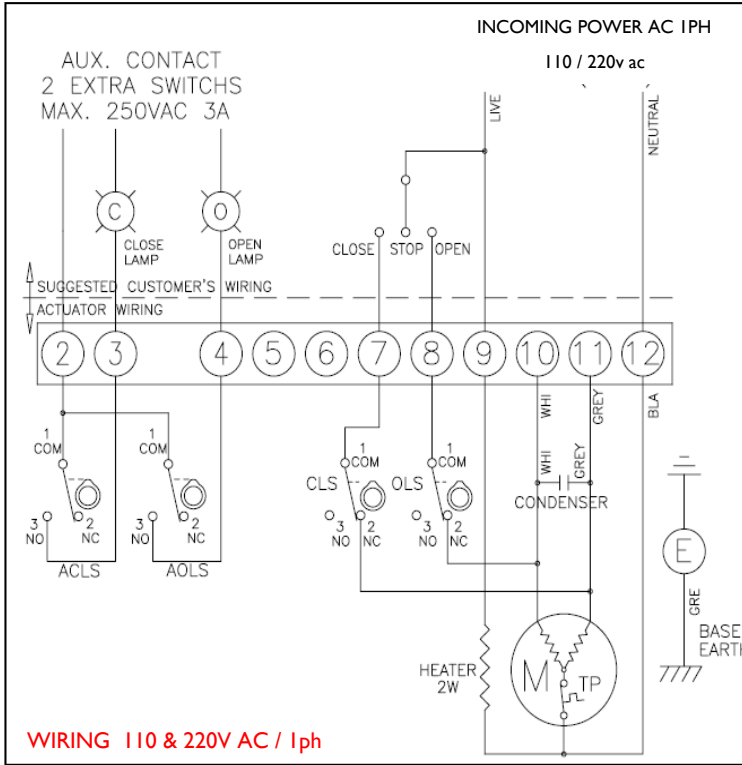

SYMBOL	DESCRIPTION	RATING
CLS	CLOSE MOTOR STOP SWITCH	250VAC 5A
OLS	OPEN MOTOR STOP SWITCH	250VAC 5A
ACLS	AUX CLOSE LIMIT SWITCH	250VAC 5A
AOLS	AUX OPEN LIMIT SWITCH	250VAC 5A
TP	THERMAL PROTECTOR	250VAC 15A

IMPORTANT NOTE:

Each actuator should be powered through its own individual switch or relay contacts to prevent cross feed

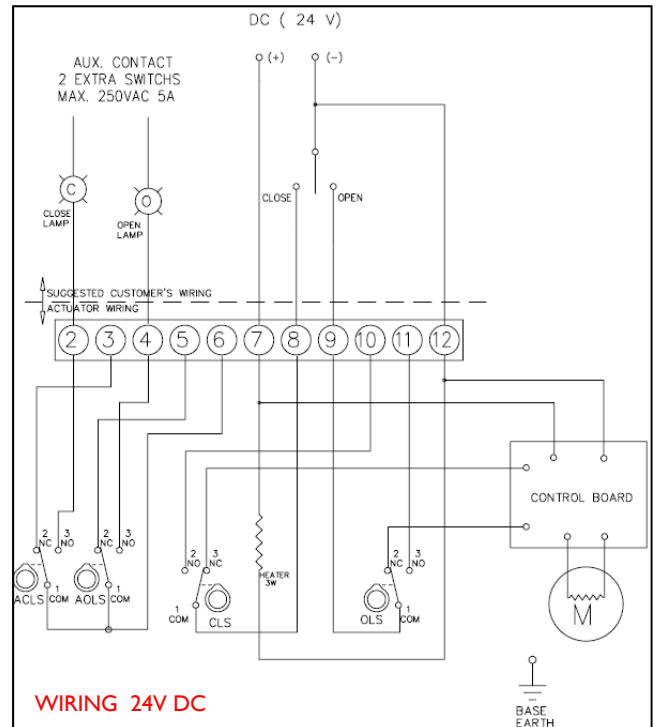
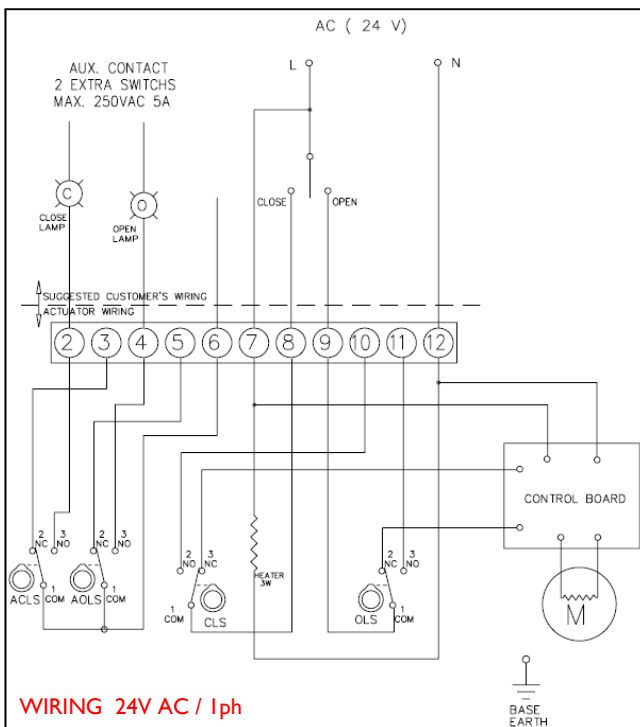



Model HQ-1103

DIMENSIONS



Doc: HQ/1103/01

Nov 2009

Electrically operated 2 way brass ball valve
- Valve & Actuator dimensions (mm)

Valve dimensions								
SIZE DN	Ø	A	B	C	F	H	S	Nm
1/2"	15	7	9	F03	17	31	59	1.0
3/4"	20	8	9	F03	18	37	69	1.2
1"	25	8	9	F03	22	41	83	1.5
1 1/4"	32	8	9	F03	24	46.5	94	2.0
1 1/2"	40	14.5	14	F05	24	58	102	10.0
2"	50	14.5	14	F05	28	65.5	124	14.0

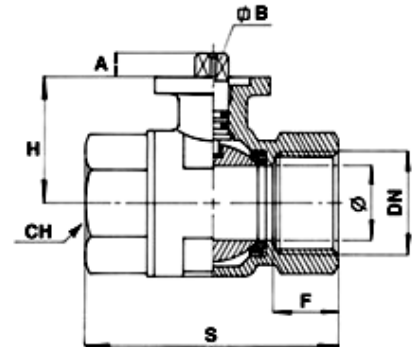

Actuator dimensions

