

J2

Model 55



Doc: J2-55/01

Nov 2006

J2 – 55 IP65 Electric Actuator

The maintenance free **J2** electric actuator is very user friendly. It offers more standard features than any rivals in its class, and was first to the market with both multi-voltage capability with automatic voltage sensing, and an electronic torque limiter with auto-gearbox relaxing which frees the manual override when a valve is jammed. The manual override facility, with a safety power cut-out switch when operated, allows safe hand operation .

Time saving external DIN plugs allow installations to be pre-wired and eliminates the need to remove the cover to connect the actuator, which helps to reduce installation costs.

With a soft start system eliminating high motor start loads and a thermostatic anti-condensation heater that does not require a separate connection, the **J2** offers low power consumption.

The IP65 weatherproof plastic housing with stainless steel cover screws offers excellent corrosion resistance.

Local visual position indication and remote volt free end of travel confirmation are provided as standard.

The **J2** is quick and easy to install:

- ISO:5211 multi-flange F05 or F07 mounting with a 17mm female double square (star) drive.
- Factory set open and closed positions at 0 and 90° (or as specified on your order).
- External electrical connections and external wiring diagram- no need to remove the cover to connect.

Always read the supplied installation & operating instructions before use.

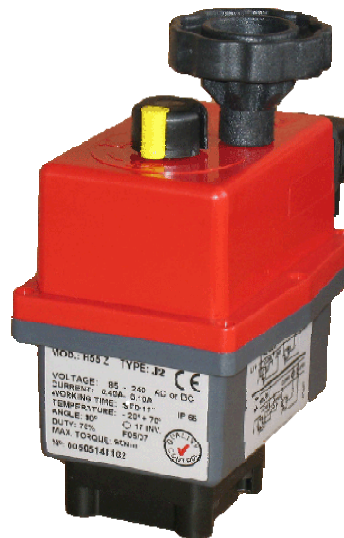

Main Features:

Multi-voltage capable with auto-voltage sensing:

J2-L55 12-48V AC/DC
J2-H55 80-240V AC/DC

Torque output:

60Nm Break

55Nm Reseat

Electronic torque limiter ~ protects against valve jams

Anti-condensation heater

Manual override

All connections via external DIN plugs ~ no need to remove the cover to connect

Volt free end of travel confirmation switches

IP65 weatherproof housing

CE marked

Traceable sequential serial numbering system

Optional failsafe with Battery Back-up - actuator fails to safe position on mains power failure

Optional modulating with digital positioning system, either 0-10V or 4-20mA control with output signal

J2 - Model 55 Options

Battery 'Spring Return' (BSR)

Power open, power to close, fails safe on power failure. Uses an industrial rechargeable battery-back up system. Can be used as energize open, fail close, subject to minimum energize open time. See individual datasheet for more information.

Digital Positioning System (DPS)

Internally factory fitted Digital Positioning System (DPS) provides accurate modulating function with either 0-10VDC or 4-20mA control signal. Output signal provided. See individual datasheet for more information.

Mounting Kit Options

ISO:5211 multi-flange mounting offers F05 & F07 fixings with a 17mm double square female (star) drive.

A full range of stainless steel mounting kits are available, typically for non-direct mount valves and for elevated temperature applications.

Specifications: J2 –55 Electric actuator (on/off)

Models	J2-H55 80-240V AC (1ph) or DC J2-L55 12-48V AC (1ph) or DC
Housing	IP65 Anti-corrosive Polyamide
Duty Rating	75%
Mounting	ISO5211 & DIN3337
Electrical Connection	External via DIN plugs
Torque Output	60Nm Break, 55Nm Run & re-seat
Temp Range	-20°C to +70°C
Working Time	15 Secs ± 10%, no load
Current 220VAC/ 110VAC	125 mA 20.9W / 400 mA 19.8W
Current 24VAC/ 24VDC	2800 mA 67.7W / 3100 mA 74.4W
Weight	2.5 kg

Dimensions:

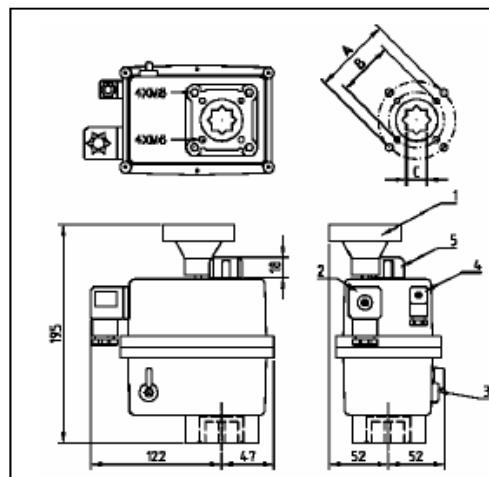

On/off, stays put on power failure:

- A: ISO:5211 F07
- B: ISO:5211 F05
- C: 17mm double square (star)
- 1 Manual override hand wheel
- 2 Power supply DIN plug
- 3 Manual override selector lever
- 4 Volt free limit switch DIN plug
- 5 Local visual position indicator

Wiring:

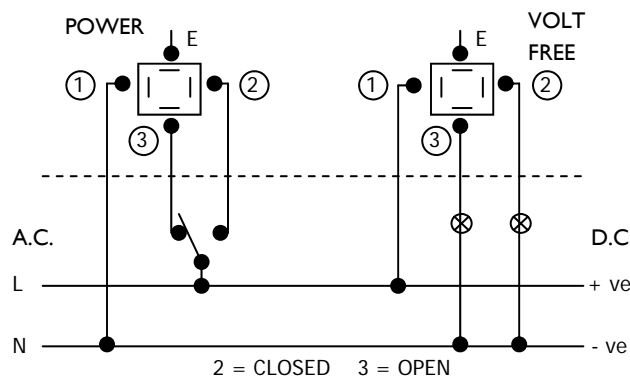

Wiring Diagram (AC or DC): 3 wire

- Notes:
- DIN plugs supplied with actuator
 - Change-over switch not supplied

J2

Installation, Operation & Maintenance Instructions

Model **J2** On/ Off



Doc: J2.STD.IOM/01

Aug 2006

INSTALLATION INSTRUCTIONS

J2 actuators operate using live electricity and we strongly recommend that only qualified electricians/ electrical engineers be employed to make electrical connections. They are quick and easy to connect without removing the cover, do not remove the cover without our authorisation or the warranty may be invalidated:

Check that the voltage being applied matches the voltage shown on the actuator's identification label and connect the power supply cables to the DIN plug(s) as per the wiring diagram affixed to the side of the actuator. Removing any label will invalidate the warranty. Wiring can be the same for AC or DC (3 wire), or 2 wire DC with a customer supplied voltage polarity switch, which is needed to reverse the motor. If in doubt, ASK BEFORE CONNECTING. Ensure that the rubber seal is refitted between the Din plug and base to maintain the IP65 seal, failure to fit the seals will invalidate the warranty. Do not over-tighten the plug securing screw.

Do not connect a power supply voltage in excess of 48V to the low voltage (**J2-L**) series as irreparable damage will be caused and any warranty invalidated.

All **J2** actuators are supplied with volt free position confirmation switches (limit switches) that require a separate power supply to operate (rated 240V 5A) The suggested wiring as per the wiring diagram affixed to the side of the actuator shows the same voltage for the actuator being used as the power source for these switches – this is a suggestion only and any standard control voltage can be used (eg: 24VDC). Do NOT use the end of travel confirmation switches to cut the power to the motor as (a) they are set around 5° ahead of the motor stop position and the actuator would therefore stop before it reaches the fully open or fully closed positions, and (b) the internal heater would be disabled as it only operates whilst mains power is being supplied to the actuator.

If the volt free plug is not being used, blank off the cable entry to the DIN plug and leave the plug fitted to the actuator to maintain its IP65 weatherproof rating. Take care not to knock the DIN plugs as this may pull the DIN plug base away from the actuator which in turn will break the body seal and permit water to access the housing. Damage of this nature invalidates any warranty.

Whilst the **J2** actuators can be fitted in any orientation we recommend installing the actuator vertically wherever possible. Be aware of applications where elevated temperatures could be present and allow for the possibility of heat rising – in these cases use an extended mounting kit to help dissipate the heat, and mount the actuator horizontally.

OPERATING INSTRUCTIONS

J2 actuators work with the use of cams that operate limit switches which control the starting, stopping, and direction of rotation of an electric motor. These cams are factory set at 0 and 90 degrees (or as per your order eg: 0-180 degrees) and whilst they are adjustable, should not normally require any user adjustment.

Supply a continuous (not pulse) live signal (either open live, or close live) to operate the actuator. The actuator will rotate until the cams operate the micro switch and cut the power to the motor. The actuator will stay in this position until a further continuous live signal is received to send it to its opposite position. The in-built heater uses this mains supply and therefore the power supply voltage should remain on at all times, this is very important where actuators are exposed to the weather.

The rest positions are as per the moulded open and closed logos (see below), indicated by a local visual position indicator (the yellow indicators show the actuator position relative to the logos).

In the case of mains power failure, the actuator will stay in the position it saw at the moment of power interruption. Should the actuator need to be operated under these circumstances, use the manual override facility, but remember to reset the selector lever in the AUTO position when the movement is completed as selection of 'MAN' cuts the power to the motor.

All **J2** actuators have an electronic torque limiter (ETL) which cuts the motor power if the applied torque exceeds the actuators rated output. To reset, cut the power, clear the cause of the excess torque eg: valve blockage, turn the power back on and the limiter will reset allowing resumption of normal operation.

MANUAL OVERRIDE

All **J2** actuators have a manual override facility, operated by a selector lever which disengages the motor drive when moved from AUTO (automatic operation) to MAN (manual operation). The gearbox contains planetary gears and it may be necessary to 'wiggle' the selector lever whilst gently moving the manual override handle to ensure the gears disengage and re-engage. When resetting into AUTO – a positive 'click' will be felt when the gears have correctly re-engaged. A safety cut out switch activated by the manual override selector lever, cuts the power to the motor when in the MAN position. When MAN is selected, the actuator will not operate electrically.

NEVER remove the selector lever retaining screw as this will allow the internal operating mechanism to become free and will cause irreparable damage to the actuator's gearbox. Removing this screw will invalidate any warranty.

When in AUTO mode, the manual override operating handle rotates on models 20 & 55 – restricting this rotation may activate the ETL. In these circumstances, switch off the power, leave a few seconds and turn back on – the ETL will automatically reset.

When in MAN mode, avoid rotating the actuator beyond the open and closed logos moulded on the top of the actuator. There are no mechanical stops fitted to the actuator (to allow rotations of 120 and 180 degrees) and it is therefore possible to over rotate the actuator. Over rotation will position the internal cams beyond their micro switches which will result in a first abnormal operation of the actuator when reset into AUTO mode (the actuator may rotate up to 450 degrees until the cam resets in the correct position).

Actuator cover has moulded open and closed logos:



OPEN



CLOSED

MAINTENANCE

J2 actuators are designed to be maintenance free, the gearbox is factory lubricated for life and there are no internal parts that require maintenance.

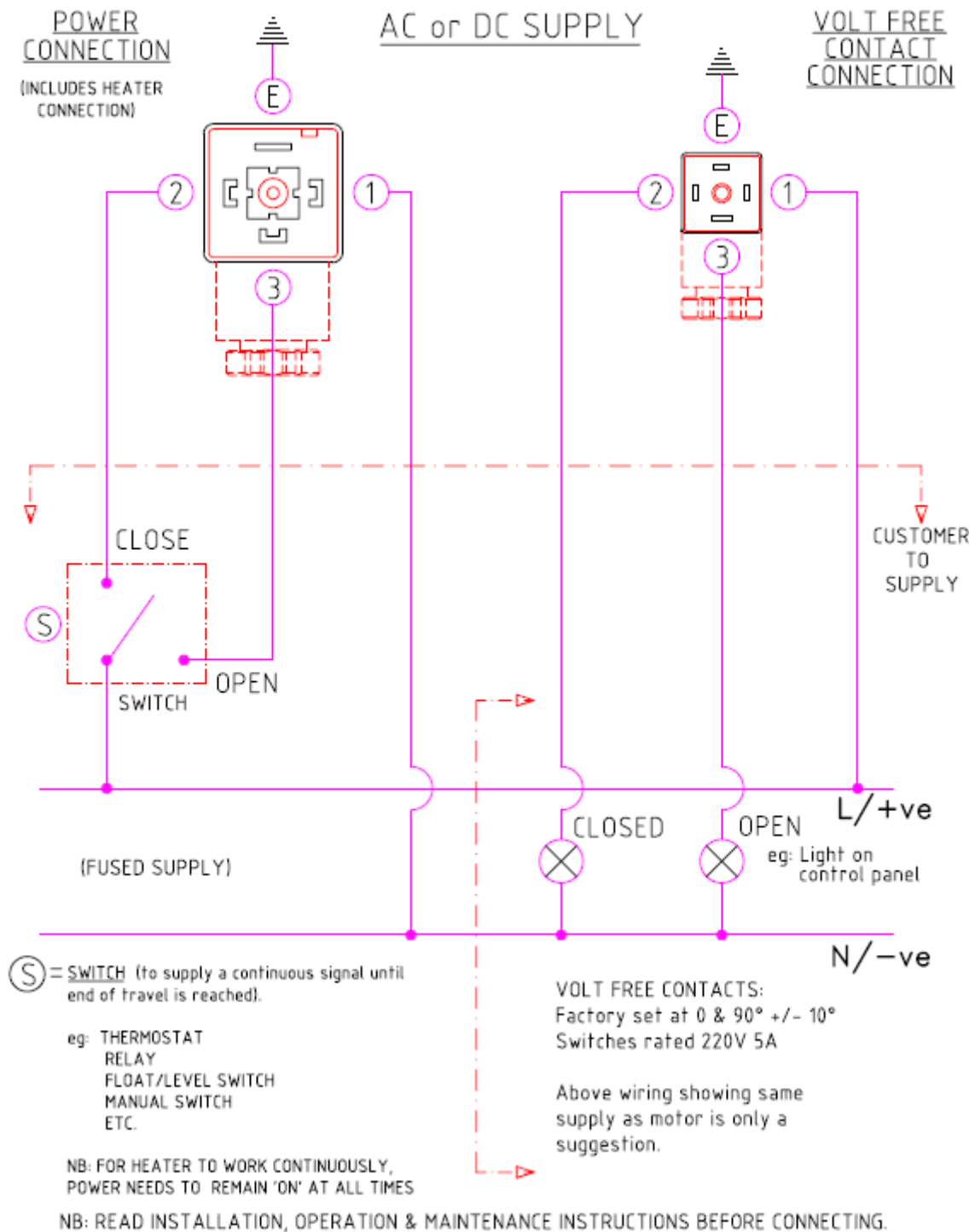

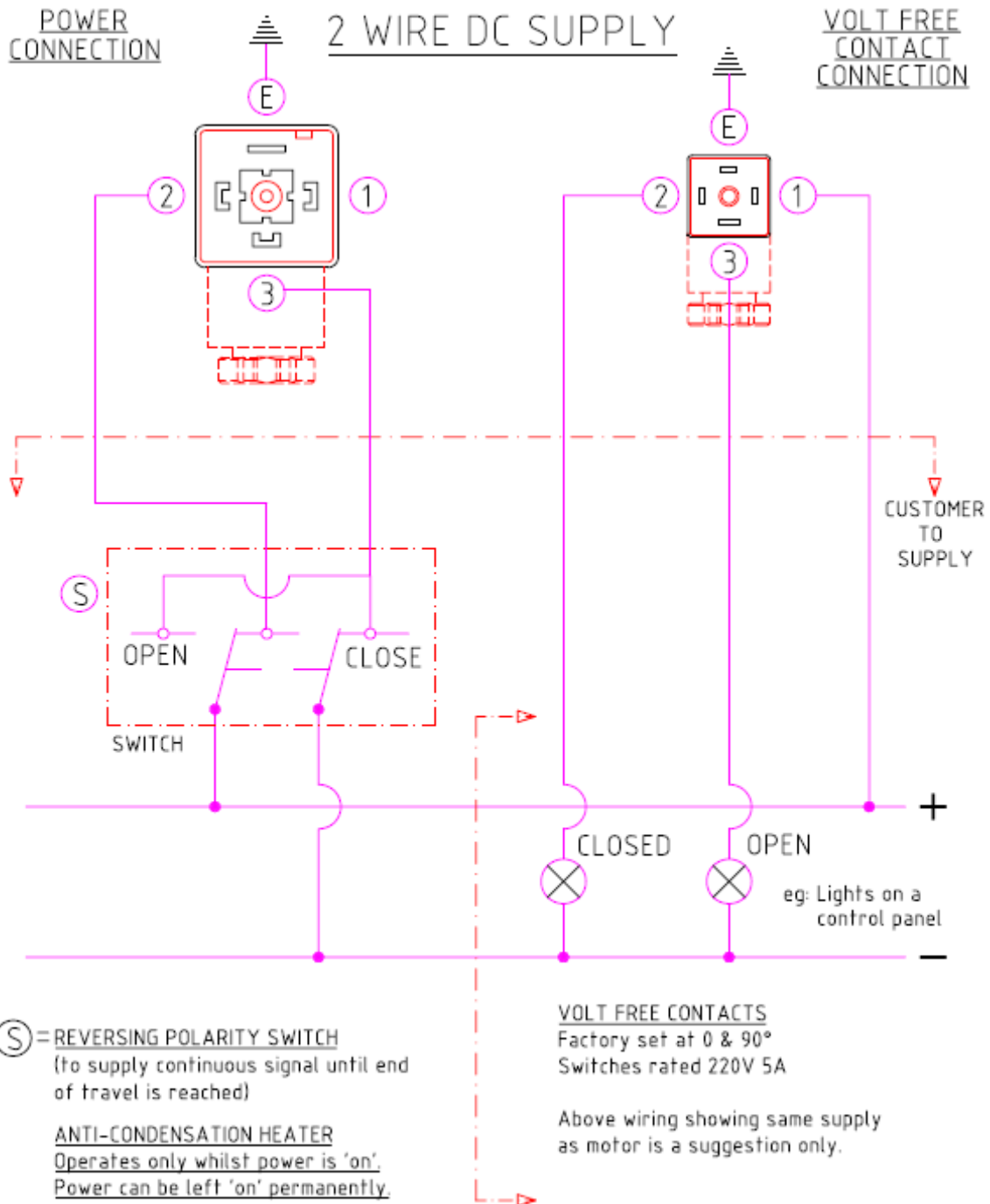

NB: READ INSTALLATION, OPERATION & MAINTENANCE INSTRUCTIONS BEFORE CONNECTING.