

# J3

## On-off multi-voltage electric actuator

with LED status light and plug & play kits for  
failsafe and/ or modulating conversion.



**Installation, Operation &  
Maintenance Instructions**



Page 1 Contents & ID label information

2 Safety and warranty instructions

3 Electrical connectors & Cable size

4 Wiring diagram

5 General information

6-9 Manual override

10 Heater and Options -- Plug & play function conversion kits

11 Electronic torque limiter

12 Mounting to valves

13 Common user errors

14 Notes

15 Maintenance & disposal instructions, and distributor information

**ACTUATOR ID LABEL**

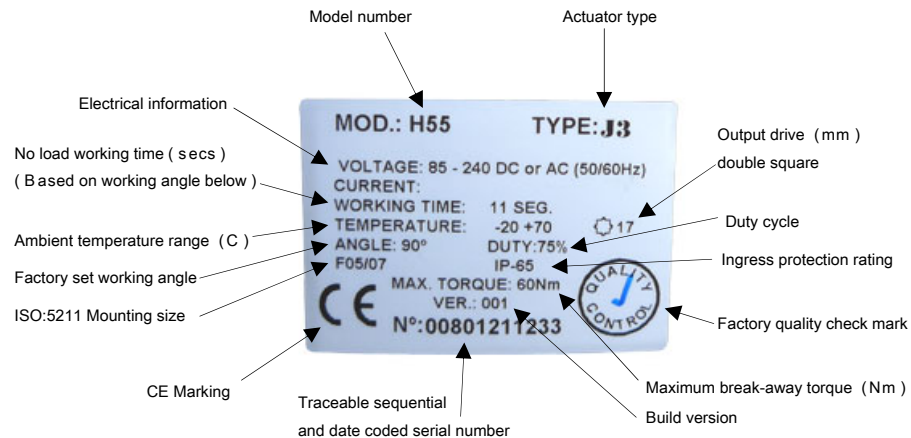

**DO NOT remove the ID label from an actuator. Removal instantly invalidates any warranty irrespective of their supply date.**



Damage caused by non-compliance to these instructions will not be covered by our warranty. Read these instructions BEFORE installing or connecting the actuator.

### SAFETY INSTRUCTIONS



J3 Electric actuators operate with the use of live electricity. It is recommended that only qualified electricians or people instructed in accordance with electrical engineering, and familiar with local health and safety directives, be involved in the connection of these actuators. It is strongly recommended that each actuator has its own independent fused system to protect it against the influence of other electrical devices connected to the system.

### WARRANTY INFORMATION

- > Every J3 electric actuator is fully tested and set at the factory.
- > The J3 electric actuator is guaranteed for 12 months from date of despatch from manufacturer against all types of manufacturing and material defects. Actuators that have failed due to faulty materials will be replaced without charge. The guarantee is limited to the replacement of the actuator only, as decided by our service department and no third party costs (eg: labour costs for removal/ replacement, production down time, etc ) howsoever arising, will be entertained. Transport costs involved in the return and replacement are chargeable.
- > The guarantee is only valid if the actuator has been installed, operated and maintained strictly in accordance with these instructions, and that the actuator has NOT been disassembled, self-repaired, incorrectly re-assembled, suffered damage caused by shocks or mal-operation, been supplied with inappropriate power supplies, used in conditions outside its specifications or working conditions, or suffered damage by practices not in accordance with sound engineering practice or common sense.
- > Where a customer has failed to maintain his credit account (where applicable) within our terms, our guarantee will be suspended for and until the payments have been brought in line, and that this suspension will not prolong the guarantee period by the length of the delayed payment.

### REPLACEMENTS FOR 'FAULTY' ACTUATORS

- > Goods must be examined immediately upon arrival and any loss or damage notified to us and the carrier (if applicable) in writing, within 24 hours of receipt, otherwise no claim will be entertained.
- > Goods can not be returned without our prior consent.
- > Where a 'failed' actuator can not be resolved by phone, any replacement actuator must be ordered using an official Purchase Order and the replacement actuator will be invoiced. Upon receipt and testing by us of the 'failed' actuator, the invoice for the replacement actuator will stand if we show that the 'failure' was caused by incorrect operation, connection, or non-adherence to these instructions, but will be credited should the failure be due to faulty materials or workmanship. Where a returned 'failed' actuator works, and is returned to the customer, the replacement actuator can only be returned if it is in unused, prime, re-sellable condition.



**ELECTRICAL CONNECTORS ( DIN Plugs )**

**Warning!**



BEFORE connecting, ensure the voltage to be applied is within the range shown on the actuator 's ID label.



Do NOT connect a voltage in excess of 24V to the ' L ' Series actuators or irreparable damage will be caused and **will NOT be covered by our warranty.**

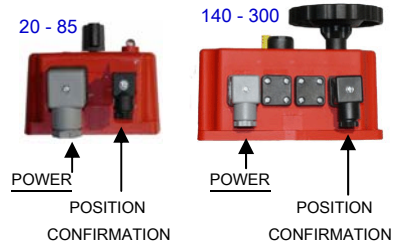

J3 Actuators are multi-voltage capable with automatic voltage sensing. All connections are made using the supplied external DIN plugs. The rotation is factory set so under normal circumstances there is no need to remove the cover to connect electrically - in fact **removing the cover may invalidate the warranty.**

The J3 has 2 voltage ranges: J3-H Series Accepts voltages from 80-240V AC ( 1ph ) or DC  
 J3-L Series Accepts voltages from 12-24V AC ( 1ph ) or DC

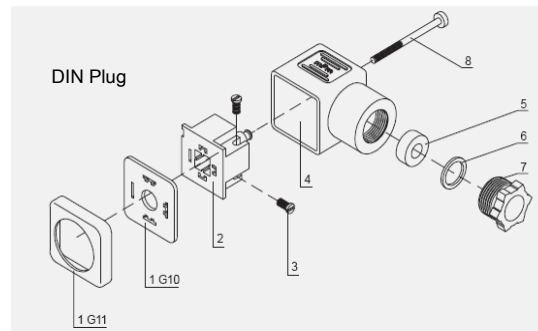

- 1 Gasket/ seal. We use G11
- 2 Terminal strip
- 3 Cable securing screws
- 4 Housing
- 5 Grommet
- 6 Washer
- 7 Gland nut
- 8 Securing screw

**CABLE SIZE**

	SMALL CONNECTOR		LARGE CONNECTOR	
	DIN:43650 ISO:4400 & C193		DIN:43650 ISO:4400 & C193	
	Minimum diameter	Maximum diameter	Minimum diameter	Maximum diameter
J3-20 thru J3-85	5 mm	5 mm	8 mm	10.5 mm
J3-140 thru J3-300			8 mm	10.5 mm

**Warning ! Water-tightness**



Ensure that the rubber gasket ( part 1 above ) is correctly installed when securing a DIN plug to the actuator. Failure to do so could allow water ingress - **damage caused by this installation error will invalidate any warranty.** Do not over-tighten the securing screw ( part 8 ) when assembling.

### WIRING DIAGRAMS FOR ON-OFF VERSION

The wiring diagram below is for power open, power close applications.

We recommend a fused independent supply for each actuator and it is very important that the power supply earth connection is made to prevent the current-free voltage on the non-live pin stopping the actuator from working. This current-free voltage disappears as soon as the motor runs, but in non-earthed systems can prevent the J3 from working.

If a 3 wire + earth power cable is to be used, select the schematic to the left below.

If a 2 wire + earth power cable is to be used, select the '2 wire system' schematic below.

A voltage polarity change-over switch will be needed for 2 wire connecting. This is not supplied with the actuator.

The position confirmation switches are volt free and can have a different voltage applied than the power supply voltage eg: 220V/1ph power supply, 24VDC for position confirmation. For ease, the schematic below shows the same voltage for both power and position confirmation. See notes on following page regarding use of the volt free contacts.

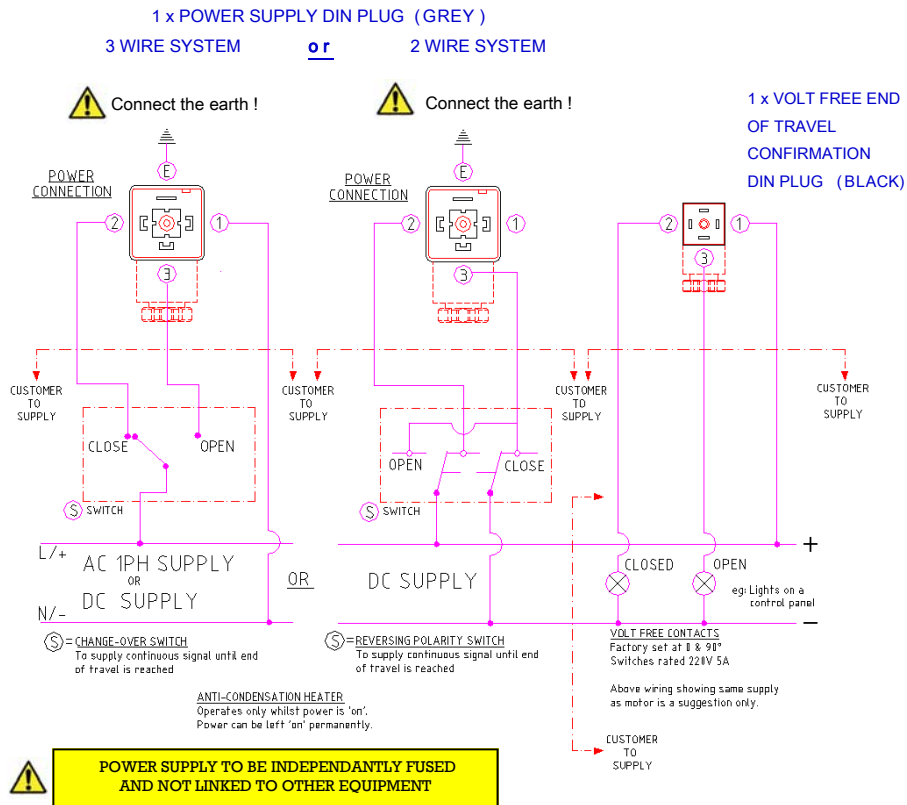



**FUNCTION: ON-OFF VERSION**

Power open, power close. Stays put on mains power failure. On receipt of a continuous power signal, the motor runs and via a planetary gearbox system, rotates the output shaft. The motor is stopped by internal cams, fitted to the output shaft, striking micro-switches which cuts power to the motor. When a subsequent continuous signal is received, the motor will turn in the opposite direction, reversing the direction of rotation of the output shaft.

**JOG CONTROL**

The actuator can be stopped and started by switching the power on to start and off to stop. Be aware that during the 'off' period the anti-condensation heater is de-energised. As we provide anti-condensation protection, damage caused by condensation is not covered by our warranty.

**DIRECTION OF ROTATION**



**REMOTE POSITION INDICATION**

2 volt free adjustable SPDT switches are supplied which are generally used for remote position confirmation. Being volt free, a different voltage can be applied to these switches than used for the power supply eg: 110V/1ph power supply, 24VDC for volt free circuit.



The volt free contacts are set around 5 degrees ahead of the final motor stop position.

Do not use the volt free signal to switch off the power as (a) the actuator will not travel to the fully open or fully closed positions and (b) the anti-condensation heater will be de-activated as it only operates whilst power is applied to the actuator ( see note above under ' Jog Control )

**OPERATING QUADRANT ( Standard 90 degree operation )**

If the actuator is rotated beyond the open and closed logos taking it outside the working quadrant ' Q ', and left outside the working quadrant when returned to ' AUTO ', mal-operation may occur .

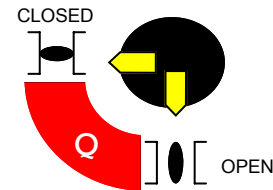

Q = Working quadrant

**VISUAL POSITION INDICATION ( 0-90 degree operation )**

A local visual indicator is provided. It is a yellow plastic insert in a black plastic base. Open & closed logos are moulded into the cover: The yellow indicator rotates in the quadrant between the logos.

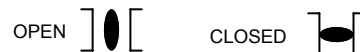

### EMERGENCY MANUAL OVERRIDE

All J3 electric actuators are provided with a de-clutchable manual override to allow manual operation should power not be available. There are 2 marked, selectable positions:

'MAN' for manual operation and 'AUTO' for automatic operation.

See following page for operating instructions

The actuator's output drive is disengaged when 'MAN' is selected, and will not respond to any command signals sent to the actuator until the selector lever is returned to the 'AUTO' position.

#### WARNINGS:



Do NOT attempt to operate the manual override operator without first selecting 'MAN' using the manual override selector lever otherwise irreparable damage will be caused to the actuator's gearbox.

Damage so caused is NOT covered by our warranty.

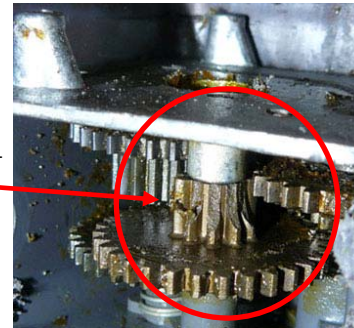

Do NOT remove the manual override selector lever retaining screw as this will allow the lever's internal parts to become loose and will cause irreparable damage to the actuator's gearbox.

Damage so caused is NOT covered by our warranty.



Do not use excessive force on the selector lever as this will cause irreparable damage to internal components.

Damage so cause is NOT covered by our warranty.



Operating the manual override will cause the LED status light to flash -- see page 8 & 9 for details

OPERATING PROCEDURE FOR SELECTING MANUAL OR AUTOMATIC OPERATION

- 1 FIRST - SELECT 'MAN' (MANUAL)

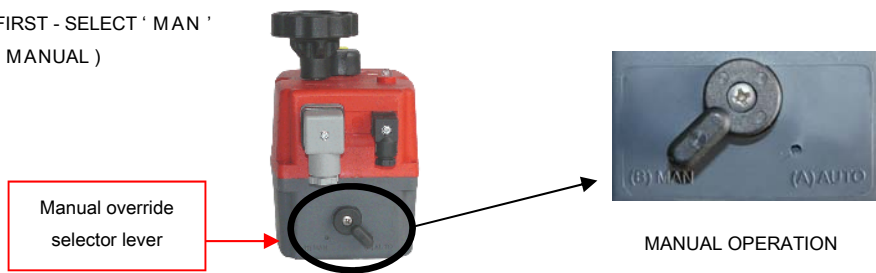

- 2 THEN - OPERATE MANUALLY

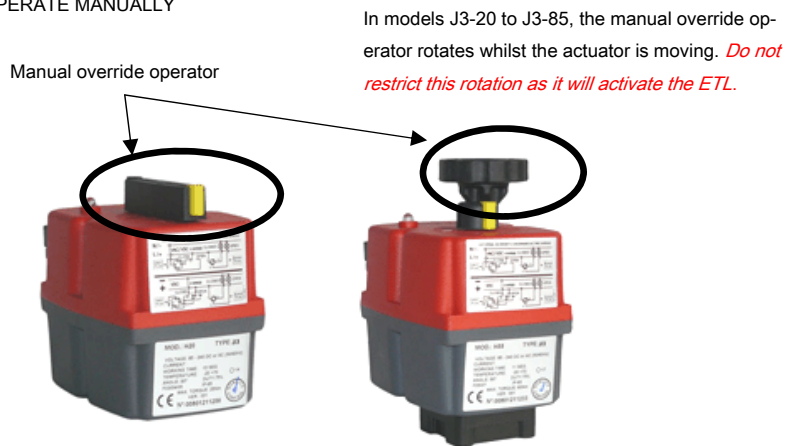

- 3 WHEN FINISHED - RETURN TO 'AUTO'

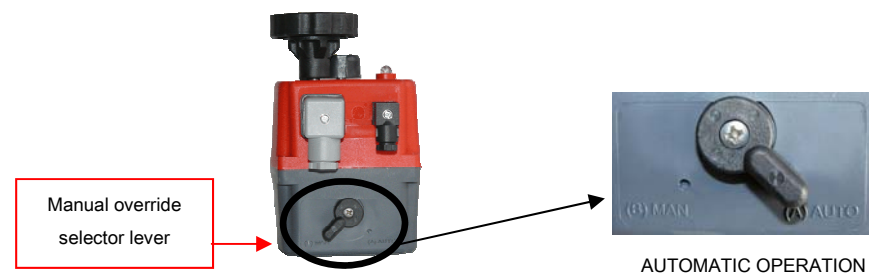

**SELECTING HAND OPERATION:**

Using the manual override selector lever, select 'MAN'. There are different situations from which 'MAN' can be selected that each receive different responses from the J3 actuator, which are outlined as follows:

	Status of actuator when switching from AUTO to MAN, & subsequent actions	Immediate response from actuator - output drive is disengaged and ...	Condition of LED status light
1 O P E N	Actuator at rest in open position, power energised, 'open' signal being sent to actuator.	No reaction	Continuously lit
	'Close' signal sent to actuator	Motor runs & times out after around 20-30 seconds	Double blink to indicate manual operation
	Actuator position moved away from 'open' position manually	Motor runs & times out after around 60-70 seconds	Double blink to indicate manual operation
2 C L O S E D	Actuator at rest in closed position, power energised, 'closed' signal being sent to actuator.	No reaction	Continuously lit
	'Open' signal sent to actuator	Motor runs & times out after around 20-30 seconds	Double blink to indicate manual operation
	Actuator position moved away from 'closed' position manually	Motor runs & times out after around 60-70 seconds	Double blink to indicate manual operation
3	Actuator in mid-travel, energised and running, and not operating either the open, or closed motor switches	Motor runs and times out after a few seconds (varies between 8-17 seconds)	Double blink to indicate manual operation
4	Actuator de-energised, in any position	No reaction	No reaction, requires power



Note: Timings may vary between different models.



*Simple "fault" diagnostics . . . . .  
If the actuator does not respond to a command signal, and the LED is flashing twice - the actuator is in manual !*

**Restoring automatic function:**

Using the manual override selector lever, select 'AUTO' . Do not force the lever or damage will be caused to it 's internal parts, this is not covered by our warranty. There are different situations from which ' AUTO ' can be selected that each receive different responses from the J3 actuator, which are outlined as follows:

	Status of actuator when switching from MAN to AUTO, & subsequent actions	Immediate response from actuator	Condition of LED status light
1	Actuator at rest in open position, power energised, 'open ' signal being sent to actuator.	No reaction	Continuously lit
	Send 'Close ' signal to actuator	Motor runs & sends actuator to the closed position	Changes from double blink to continuously lit
2	Actuator at rest in open position, power energised, 'closed ' signal being sent to actuator.	No reaction	Continuously lit
	Send 'Open ' signal to actuator	Motor runs & sends actuator to the open position	Changes from double blink to continuously lit
3	Actuator in mid-travel and not operating either the open, or closed motor switches	Motor runs & sends actuator to the signalled position	Changes from double blink to continuously lit
4	Actuator at rest, energised, outside the working quadrant, either open or closed signal being sent to actuator .	Motor starts and actuator starts to move when opposite signal sent.	Changes from double blink to continuously lit.
	 Operational error !	After around 17seconds the actuator stops, wherever it is	Changes from continuously lit to double blink even though the selector lever is in AUTO
5	Actuator at rest, de-energised, outside the working quadrant.	No reaction	No reaction, requires power
6	Actuator at rest, initially de-energised, outside the working quadrant, then energised with either an open or close signal.	If AUTO is selected BEFORE the time out occurs, the actuator will arrive at the signalled position .	Changes from double blink to continuously lit .
	 Operational error !	If AUTO is selected AFTER the time out occurs, after around 17 seconds the actuator stops wherever it is	Changes from continuously lit to double blink even though the selector lever is in AUTO
7	Actuator de-energised, in any position within the working quadrant	No reaction	No reaction, requires power

Note: Timings may vary between different models.

### ANTI-CONDENSATION HEATER



The J3 actuator has a thermostatically controlled anti-condensation heater that maintains the actuator's internal housing at around 30°C. The heater is activated whenever mains power is connected to the actuator. We strongly recommend that power remains 'on' at all times to protect the actuator from the damaging effects of condensation. As we supply an anti-condensation heater as standard, **damage caused by condensation is not covered by our warranty.**

### OPTIONS - FUNCTION CHANGE

The J3 on-off actuator is capable of having its operating function changed by the fitting of plug and play conversion kits, 2 kits are available, a failsafe and a modulating kit, and either one, or both can be retro-fitted. Full details and instructions are supplied with the kits.

#### BSR Failsafe System (Battery 'Spring Return')

This system simply stores power in a re-chargeable industrial battery pack that instantly discharges when mains power is interrupted. During normal operation the actuator functions as an on-off actuator and simultaneously trickle charges the battery pack to maintain it at full charge. A short re-charge time is required following each discharge to replace the power used. The main advantage of this system is it is far less expensive than a true mechanical spring return system as the actuator size remains the same as there are no springs to compress.

The BSR is supplied in a boxed kit.  
Kit shown covers Models 20-85



#### DPS Positioning System (Digital Positioning System)

This system provides modulating control whereby the movement of the actuator is totally controlled by an input signal (either 4-20mA or 0-10VDC), the degree of movement of the actuator being proportional to the change in the input signal. The system is digital and constantly compares the position of the actuator's output shaft relative to the input signal, and automatically adjusts the actuator's position should the actuator's position and the input signal not be equal. A feedback signal is provided as standard.

The DPS is supplied in a boxed kit.  
Kit shown covers Models 20-85



### ELECTRONIC TORQUE LIMITER with auto gearbox relaxing

All J3 electric actuators are protected against the possible mechanical drive train damage caused by a valve blockage or jam. This protection is provided by an electronic torque limiter ( ETL ) in an internal micro-chip that is programmed to constantly measure and compare the motor load against a factory set maximum.

As torque is directly proportional to motor load, as the torque increases the motor load increases. The ETL closely monitors the rate of increase in motor load as the valve starts to come to rest at the jam, and as this occurs the motor load exceeds the factory set maximum and the ETL is activated, instantly cutting the power supply to the motor.

As the valve nears the jam point, the planetary gears are being driven hard in the direction of the jam, and at the jam point, they too are physically jammed. This would make selecting ' MAN ' to put the actuator in manual mode to assist in clearing the jam impossible - to eliminate this difficulty, the ETL, a few seconds after cutting the power to the motor, moves the actuator a few degrees in the opposite direction of the jam, to relax the gears.



Activating the electronic torque limiter triggers a change in the LED status light from continuously lit to an on-off flashing sequence.

The J3 allows the user to apply a reversing command signal to the actuator ( in the opposite direction to the jam eg: if the actuator was closing, an open signal will be accepted ) to power the actuator away from the jam. In many cases, this allows the flowing media to help clear the jam as this can be done several times, and prevent the user from having to shut the system down to dismantle the valve to clear the jam.



Sending a reversing signal will change the flashing LED to continuously lit. When the actuator is subsequently send back in the direction of the original jam, if it has not cleared the electronic torque limiter will be activated again and the LED will start to flash on - off.

### Simple "fault" diagnostics . . . . .



*If the actuator will not respond to a command signal and the LED is flashing on-off, the electronic torque limiter has activated indicating that the torque required to turn the valve has exceeded the maximum output of the actuator.*

*The user instantly knows that there is a problem with the valve, not the actuator.*

### MOUNTING TO VALVES OR OTHER 1/4 TURN PRODUCTS

J3 Actuators have mounting facilities in accordance with ISO:5211 and DIN:3337 allowing them, in many cases, to mount directly onto similarly compliant valves without the need for a mounting kit ( bracket and drive adaptor/ connector) . The main advantages of direct mounting the actuators is to greatly assist in ensuring concentricity of the actuator output drive with the valve stem which eliminates side loadings and resulting increased wear on the valve stem and seals, reducing the effects of backlash in the drive train as there are fewer parts connected, and allowing valves to be part dismantled for installation into the pipe without disturbing the valve to actuator connection ( 3 piece ball valves ) .



Models: J3-20 and J3-35  
 Mounting: F03, F04 and F05  
 36mm, 42mm and 50mm PCD  
 Output: Std: 14mm double square ( star )  
 9 and 11mm options



Models: J3-55 and J3-85  
 Mounting: F05, and F07  
 50mm and 70mm PCD  
 Output: Std: 17mm double square ( star )  
 14mm option

Models: J3-140 and J3-300  
 Mounting: F07, and F10  
 70mm and 102mm PCD  
 Output: Std: 22mm double square ( star )  
 17mm option

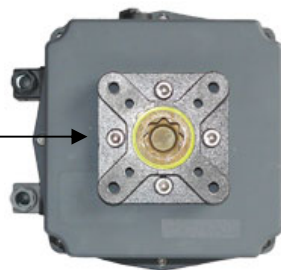

The drive being inserted into the actuator 's female output drive must NOT be longer than the maximum depth of the female drive when the assembly is bolted together. Resulting damage to the actuator and assembled components **will not be covered by our warranty.**

Common user errors identified from returns:

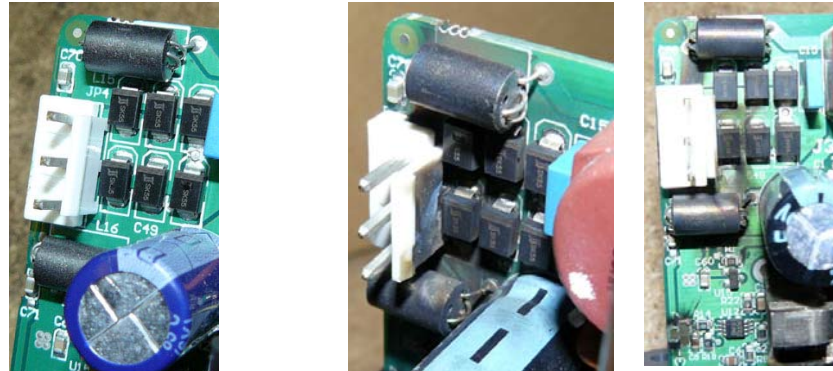

1: Damage to PCB caused by applying in excess of 24V to J3-L series actuator

Left photo: New actuator, Center & right photos show damaged PCB.

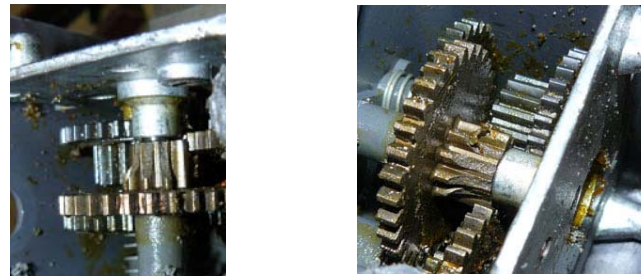

2: Damage caused by operating the manual override without first selecting 'MAN'



3: Many actuators are returned to us with the manual override set in 'MAN' (manual)

In 'MAN', the actuator will not work electrically. To work it has to be in 'AUTO'

Notes:

**MAINTENANCE INSTRUCTIONS**

The J3 actuators are generally maintenance free. There are no internal parts that require maintenance. The gearbox is lubricated for life when built at the factory. The housing may be cleaned with a cloth covered in warm soapy water to keep it clean. Do not use solvents.



**DO NOT PRESSURE WASH.** Pressure washing will invalidate any warranty



**DISPOSAL AT END OF LIFE - RECYCLING**

In the EU, this product is required by law to be recycled under the EU WEEE Directive No: 2002/96/EC. JJ actuators can be recycled by us, we are a government registered WEEE producer under the B2B scheme, Producer Registration No: WEEE/JC0052TQ.



**TECHNICAL SUPPORT HELP LINE**

Technical support is available during the following hours, UK time  
Monday to Thursday 09:00 to 17:00 hrs  
Friday 09:00 to 16:00 hrs



+44 (0) 1386 552254

Distributed by: