

Smart Positioner
YT-2400 Series

USER'S MANUAL

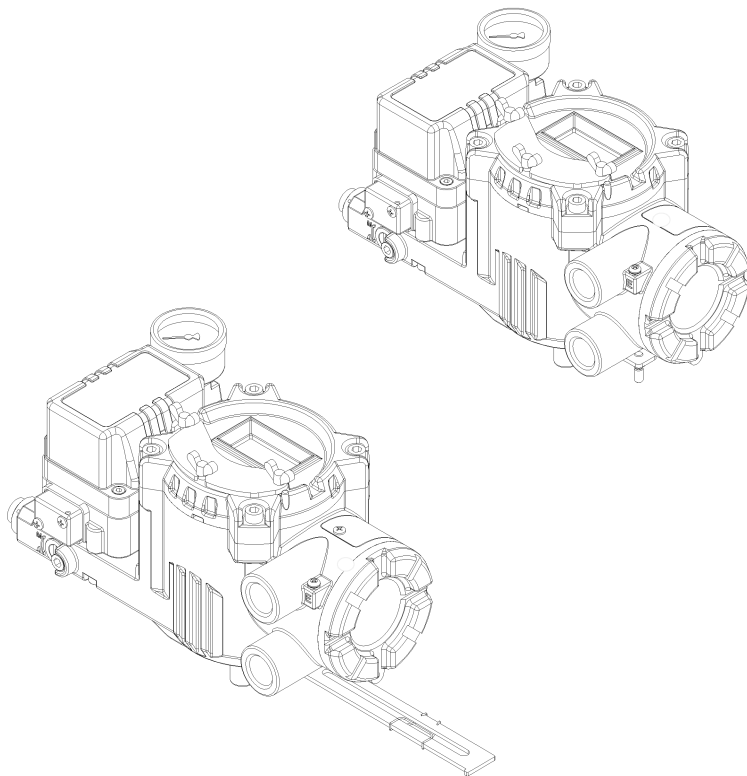

YTC

V.1.04

-Content-	
Content	1,2
Warning	3
Manual description	5
Notes on safety and warranty	5
Notes on maintenance of explosion proof structure in hazardous area	6
Product description	7
Features and functions	8
Nameplate description	9
Ordering number	10
Specifications	11
Structure	12
Installation	13
Notes	13
YT-2400L drawing	13
YT-2400R drawing	14
Tools for installation	15
YT-2400L installation	15
Example	15
Installing YT-2400L with bracket	16
YT-2400R installation	20
Example	20
Installing YT-2400R with bracket	21
Piping connection	24
Note	24
Conditions of supply pressure	25
Conditions of pipe	25
Piping connection with actuator	25
Single acting actuator	25
Double acting actuator	26
Power connection	27
Notes	27
Terminal connection of current input signal	28
Terminal connection of feedback signal	29
Terminal connection of limit switch	30
Terminal connection for ground	31

A/M switch	32
Variable orifice	32
Auto calibration and basic operations	33
Button	33
RUN mode	34
First Auto calibration	34
Entire modes and functions	35
Auto calibration (AUTO CAL)	35
Auto 1 calibration (AUTO 1)	36
Auto 2 calibration (AUTO 2)	37
Auto 3 calibration (AUTO 3)	37
BIAS calibration (BIAS)	37
Velocity calibration (V_0)	37
Manual mode (MANUAL)	38
Parameter mode (PARAM)	39
Parameter types	39
Parameter adjustment	39
Deadzone (dEAdZONE)	39
P control (KP)	40
I control (KI)	41
D control (KD)	42
Hand calibration mode (HAND CAL)	43
Hand calibration types	43
Adjustment of valve zero and end point	43
Adjustment of transmitter zero and end point	44
Valve mode (VALVE)	46
Adjustment of acting type (ACT)	46
Adjustment of characteristics (CHAR)	47
Adjustment of user characteristics (USER SET)	47
Adjustment of Tight Open mode (TSHUT OP)	49
Adjustment of Tight Close mode (TSHUT CL)	49
Adjustment of split range (SPLIT)	50
View mode (VIEW)	50
Error and warning code	51
Main software map	53

Warning

The below informations are related to explosion proof so please note that operations/distribution should be handled with great card.

- (1)Cover open after power off
After operation, close the cover then tightly fix it by using the screw
be careful for screw thread damages
Be careful for any deformity by shock
- (2)Don't loose the bolt.
Be careful for any deformity by shock
- (3)Don't loose the bolt.
Be careful for any deformity by shock
- (4)Don't loose the bolt.
Be careful for any deformity by shock
- (5)Be careful for missing of "E-stopping ring"
Be careful for any deformity by shock

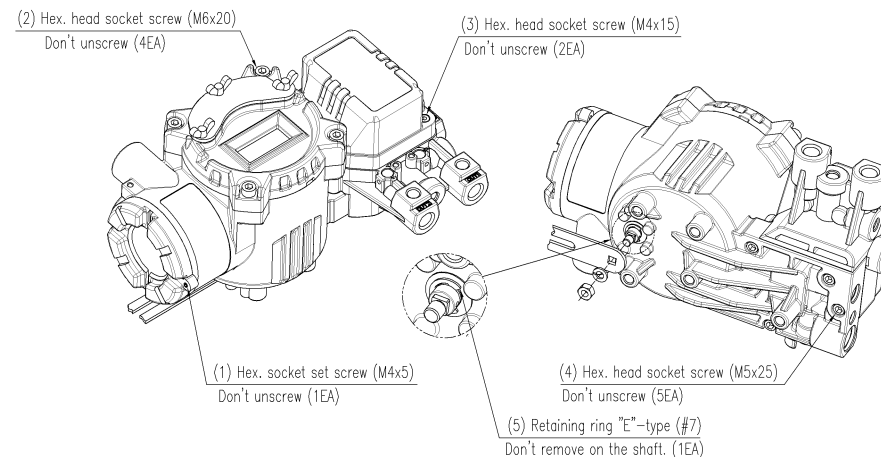

(6) Specific safety instruction

These products are manufactured in accordance with the special conditions as belows regarding to Explosion proof

This part is controlled by tight tolerance so needed very careful attention when it is used.

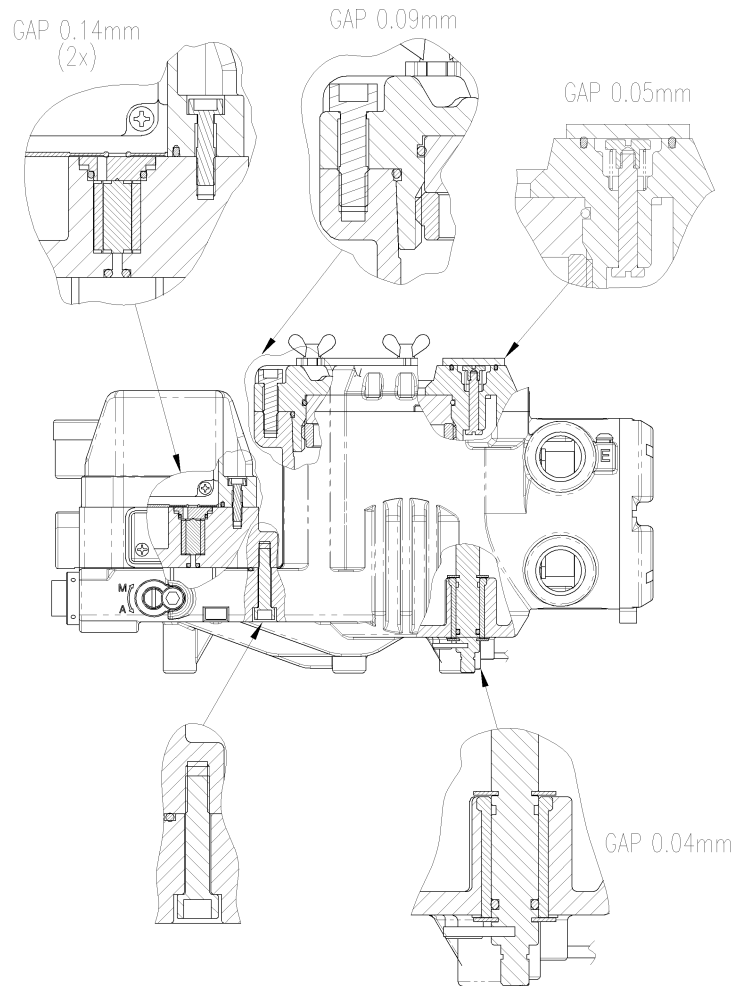

Manual description

Thanks for purchasing our products.

Our products are produced and inspected under the strict standards. In order to use the products appropriately and efficiently we recommend that users read this manual carefully and fully understand.

* This manual should be delivered to the end user.

* This manual can be changed without prior notice.

* This manual, in whole or part, shall not be transcribed or copied without approval by YTC.

* Changes of specification, structure and components may not lead to the immediate revision of this manual.

Notes on safety and warranty

* Before handling YT-2400, it is absolutely imperative that users read and observe the safety instructions in this manual in order to ensure the protection and safety of operators.

* We do not have responsibility for the damage caused by users' repair or conversion of the item. If the repair or conversion is necessary, submit inquiries.

* Warranty period is marked on the quotation sheet, which is free of charge in principle.

* For the following cases some cost shall be charged.

- Inappropriate maintenance by users
- Inappropriate transportation and storage
- The use of product beyond specification.
- Inappropriate installation
- Uncontrollable disaster such as fire, earthquake, storm, flood, etc

<http://www.ytc.kr>

Notes on maintenance of explosion proof structure in hazardous area



- * Confirm the operating conditions that explosion proof is available, and ensure not to use beyond its condition.
- * The explosion proof of YT-2400 is flame-proof, which is marked as ExdIIBT6. And it can be used in Zone 1, 2. and Having 9 engaged threads.
- * In hazardous area existing explosive gas, explosion proof type conduit tube or pressure-proof packing cable must be used. In case of using the former one, ensure to be fully sealed with using gasket.
- * When the power is connected, do not open the cover of the part that power is connected like terminal or PCB. Confirm if the power is shut down before open the cover.
- * In case of opening the cover of terminal or PCB, the current or voltage must not be remained in inner cables or electronic parts after power is shut down.
- * YT-2400 has two conduit entries. When explosion proof type conduit or pressure-proof packing cable is used, if only one port is used, the other port must be blocked by explosion proof blind plug.<providing at least 9 engaged threads>
- * For power connection, use the cable rug which sectional area is more than 0.195mm² with M4 spring washer to prevent the nuts from being loose.
- * For wiring of outside ground terminal, use the cable rug which sectional area is more than 5.5mm².
- * Install the fuze less than 62mA of rated short circuit current on outside control part.

<http://www.ytc.kr>

Product Description

YT-2400 Smart Valve Positioner controls valve stroke accurately according to input signal of 4-20mA being input from controller. In addition, highly efficient microprocessing operator built in the product performs various and powerful functions like Auto calibration, PID control, Alarm and Hart protocol.

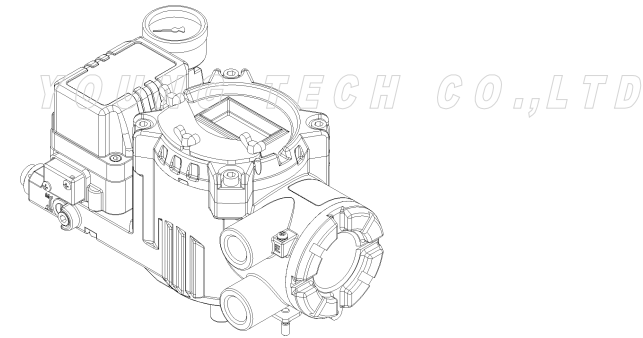

YT-2400R Smart Positioner

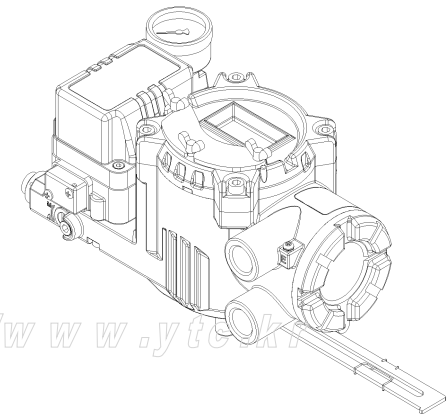

YT-2400L Smart Positioner

<http://www.ytc.kr>

Features and functions

1. There are 4 buttons on outside of product, which makes to adjust parameter, etc without opening cover in explosive gas area.
2. It is ExdIIBT6 explosion proof and can be used in ethylene explosion proof area.
3. It endures severe vibration.
4. Since pilot relay valve is installed on the outside of product body, it is available to assemble or disassemble independently.
5. It is operated normally regardless of change of supply pressure during operation.
6. Auto calibration method is very simple.
7. It is easily equipped on small actuator because of its small size.
8. Air consumption is so small that operating cost in huge plants is decreased.
9. Because it can be used in low voltage (8.5V), there is no limitation in controller.
10. Variable orifice is applied and so in case of small actuator the hunting is controlled to the optimum condition during operation.
11. Hart communication makes to process various information of valve and positioner.
12. Valve system is stable by outputting analog feedback signal.
13. Alarm function is available with using Limit switch.
14. The adjustment of Valve characteristics (Linear, Quick open, Equal percentage) is available.
15. Specific flow control is available with setting 16 point at users' command.
16. Tight Shut-Close and Shut-Open can be set voluntarily.
17. The pressure of Air filter regulator is sent to Actuator directly with using A/M switch.
18. Split range such as 4-20mA, 12-20mA is available.
19. Setting Zero and Span as partial section is available by Hand Calibration function.
20. Product reliability gets higher with self-diagnosis function.
21. The valve defect is easily checked because the valve can be operated voluntarily by Manual Operation.
22. It has IP 66 protection grade.
23. Air filter regulator can be attached with the product with only one linear nipple without extra piping.
24. Because of Epoxy polyester powder coating, it can be used for long period of time in corrosive air.
25. Because of simple and modularized inner structure, maintenance is very easy.

Nameplate Description

Model number

Product model name and additional option codes

Refer the next chapter for detailed ordering number.

Explosion proof

Explosion proof grade applied to the product

It is Flame-proof explosion proof, which is applied to ethylene gas.

**Ambient temperature**

Ambient temperature range that explosion proof certificate is available

Setting is done from -20°C to 60°C. (* Operating temperature range is -20°C to 85°C)

Ser./Date

The numbers given each product

By tracking this number various information for the item can be collected.

Input signal

Current input signal range

DC 4-20mA current is used.

Supply pressure

Supply pressure range inputting product

It is set as 1.4-7 kgf/cm² (0.14-0.7 MPa).

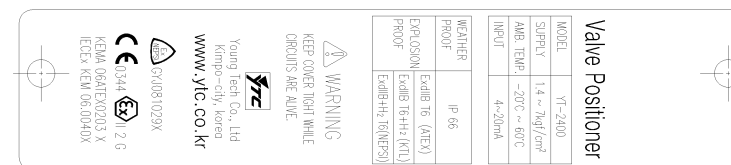
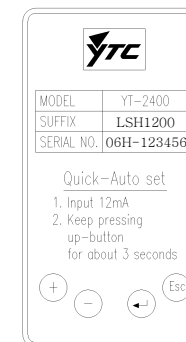

YT-2400 Label

Ordering number

YT-2400 series use the following ordering numbers.

YT-2400 □ □ □ □ □ □ □

Motion type	L : Linear R : Rotary
Acting type	S : Single acting D : Doble acting
Explosion proof	H : Ex d IIB T6
Feedback lever (YT-2400L)	1 : 10 ~ 40 mm 2 : 20 ~ 70 mm 3 : 50 ~ 100 mm 4 : 100 ~ 150 mm (note 1)
Feedback lever (YT-2400R)	1 : M6 x 40L 2 : M6 x 63L 3 : M8 x 40L 4 : M8 x 63L 5 : Namur standard
Connection type	1 : PT 2 : NPT
Communication	0 : None 2 : Hart communication
Option	0 : None 1 : Position transmitter 2 : Limit switch 3 : Position transmitter & Limit switch

Note 1. No. 4 lever (100 ~ 150mm) is connected one of No. 2 and No. 3 lever.

<http://www.ytc.kr>

Specification

Model	YT-2400L		YT-2400R	
	Single	Double	Single	Dpuble
Acting Type				
Input Signal	4~20 mA DC			
Minimum Current Signal	3.2mA(Standard), 3.8mA(Hart Included)			
Supply Pressure	1.4~7kgf/cm ² (0.14~0.7 MPa)			
Stroke	10 - 150 mm		60 - 90°	
Impedance	Max.500 Ohm/20mA DC			
Air Connection	PT 1/4, NPT 1/4			
Gauge Connection	PT 1/8, NPT 1/8			
Conduit Entry	PF(G) 1/2(Standard), NPT1/2(Option)			
Explosion proof	Ex d IIB T6			
Ambient Temperature	Explosion proof : -20~60℃ Operating range : -20~80℃			
Linearity	±0.5% F.S.			
Hysteresis	0.5% F.S.			
Sensitivity	±0.2% F.S.			
Repeatability	0.3% F.S.			
Flow Capacity	70 LPM			
Air Consumption	below 2 LPM (sup=1.4K), below 3 LPM (sup.=7K)			
LCD Temp. Condition	Storage Temp:-30~85℃, Operating Temp:-10~70℃			
Output Characteristic	Linear, Quick Open, EQ%, User Set (16 Point)			
Vibration Effect	6G			
Humidity	5-95% RH at 40℃			
Communication (Option)	HART Communication (Non-DDL)			
Feedback Signal (Option)	4-20mA (DC 10 - 30V)			
Material	Aluminum Diecasting			
Weight	3.4 kg (7.5 lb)			
Painting	Epoxy Polyestere Powder Coating			
Color	Black			

1. Based on temperature 20℃, absolute pressure 760mmHg and relative humidity 65%
2. Contact us for the product beyond the specification.
3. To change Product color or to use user's own label is available, but they are limited to the big volumes of quantity. Contact our sales dept.

Structure

The structure of YT-2400L is as follows. That of YT-2400R is as same as linear type except feedback lever.

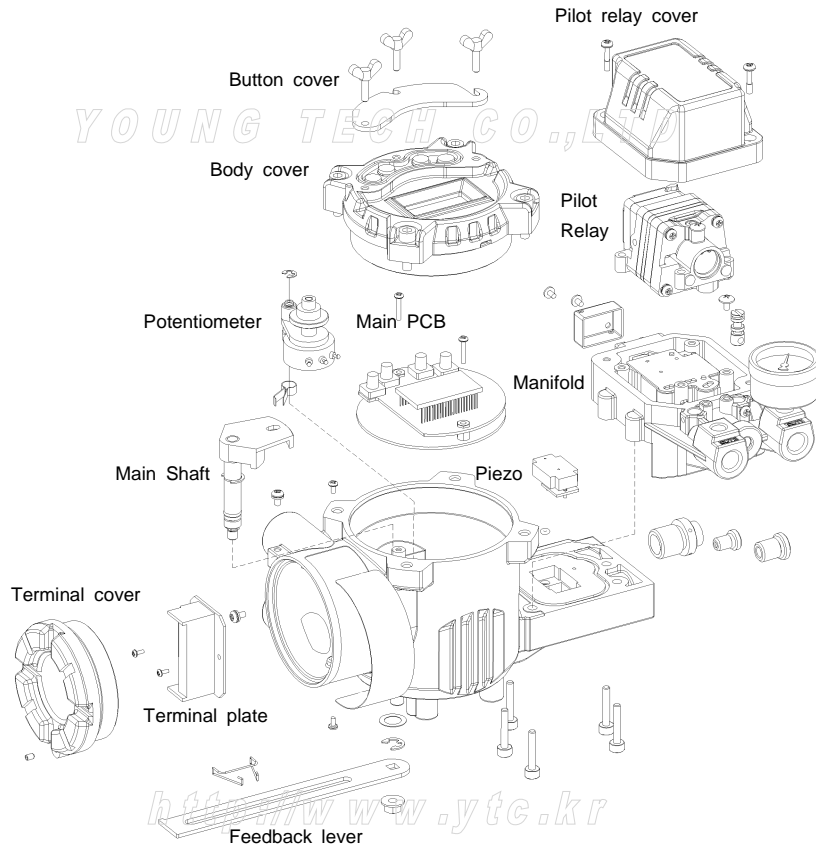

YT-2400 Structure

Installation

Note

When the positioner is installed with the actuator or replaced, ensure the followings.

- All inputs and supply pressure to valve, actuator and other instrument must be shut down.
- In order entire system not to shut down the control valve must be separated from the system by bypass valve or other equipment.
- No pressure remains in the actuator.

YT-2400L drawing

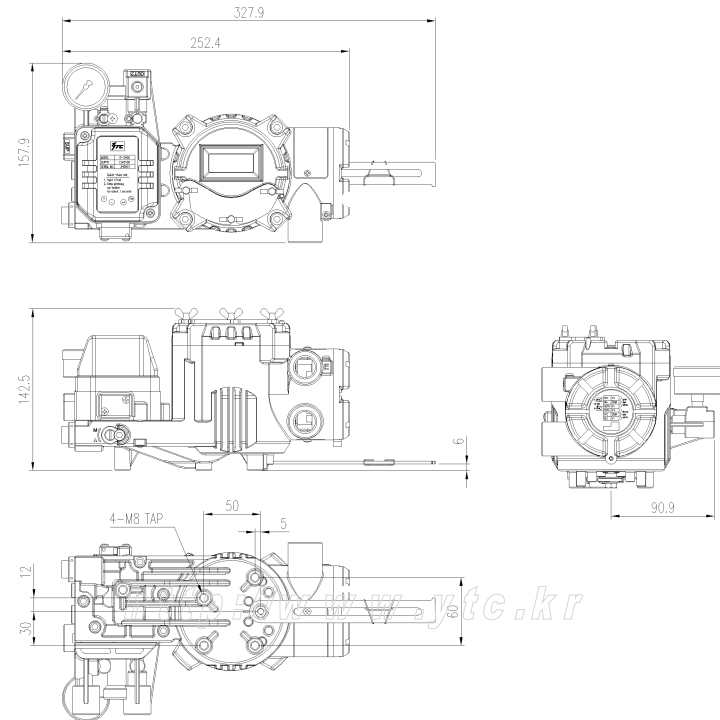

YT-2400L drawing

YT-2400R drawing

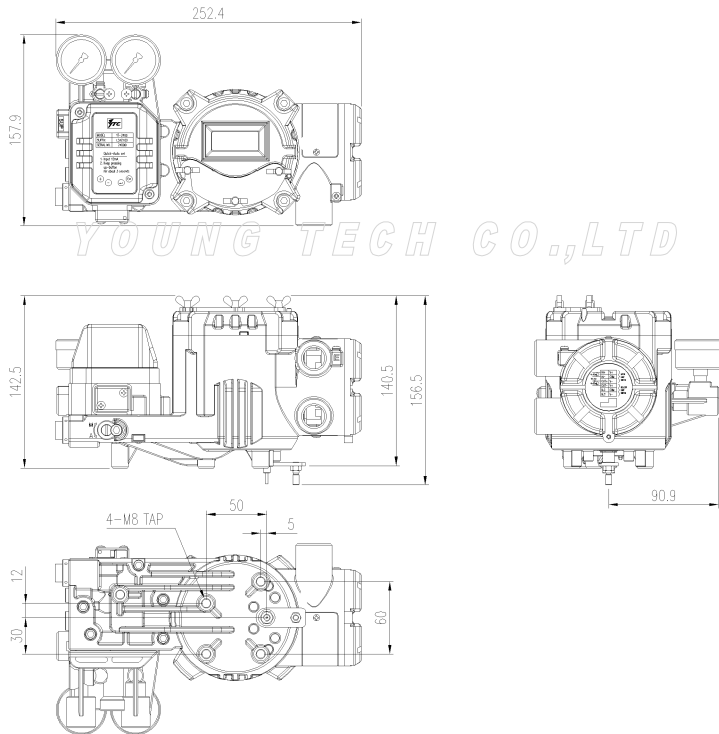

YT-2400R drawing

<http://www.ytc.kr>

* The brackets for attaching on the actuators are made by using these drawings and they are also used for checking piping, etc.

Tools for installation

Tools and bolts used for assembly are,

1. Hexagonal wrenches
2. (+) screw driver
3. (-) screw driver
4. Spanners for hexagon head bolts

YT-2400L installation

YT-2400L is used for linear motion valve such as globe valve or gate valve using spring return type diaphragm actuator or piston actuator. YT-2400L consists of the following components. Be sure that all the components are prepared.

1. YT-2400 main body
2. Feedback lever and lever spring
3. Flange nut (attached on the bottom of main shaft of YT-2400L body)
4. 4pcs of Hexagon head bolt M8x1.25P
5. 4pcs of M8 plate washer

YT-2400L installation example

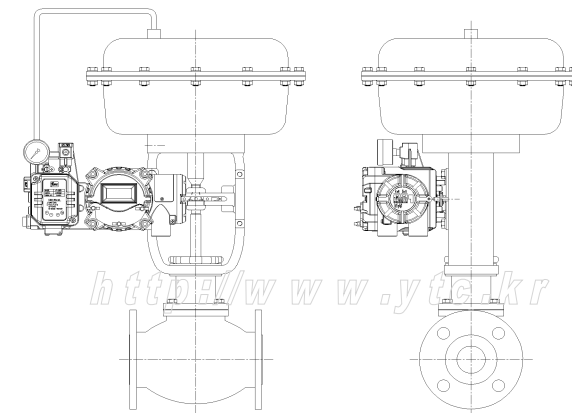

YT-2400L installation example

Installing YT-2400L with bracket

1. First of all, it is necessary to make proper bracket to attach on actuator yoke. The most important things in making bracket are as follows.

- 1) YT-2400L feedback lever should be level at 50% of valve stroke. (Refer to no. 7 in this chapter.)
- 2) Feedback lever connection bar of actuator clamp should be connected at the position that valve stroke and the numbers carved on feedback lever is fitted. (Refer to no. 8 in this chapter.)

If the bracket meets the above conditions, YT-2400L is installed very easily.

2. Assemble YT-2400L and bracket with bolts. Use standard bolts in bolt holes on the backside of YT-2400L. The standard of bolt screw is M8x1.25P and other bolt standards are available as option. For details, contact our sales dept.

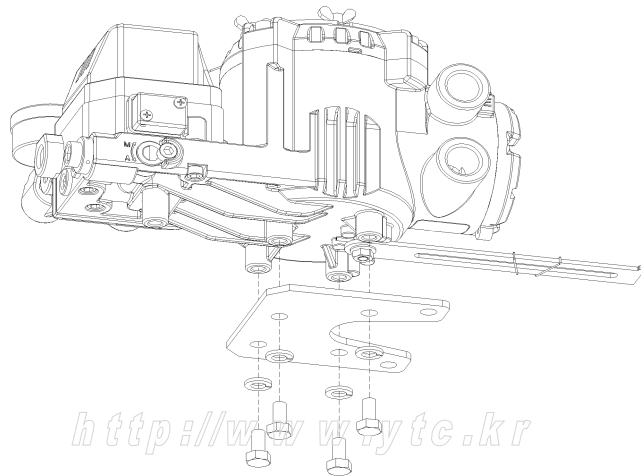

Installing YT-2400L with bracket

3. After assembling YT-2400L and bracket with bolts, attach it with using bolt holes of actuator yoke. But do not attach completely. There must be some space.

4. Install bar connected with YT-2400L feedback lever on the actuator clamp. The slot length between YT-2400L feedback lever is 6.5mm, so the diameter of connection bar should be less than 6.3mm.

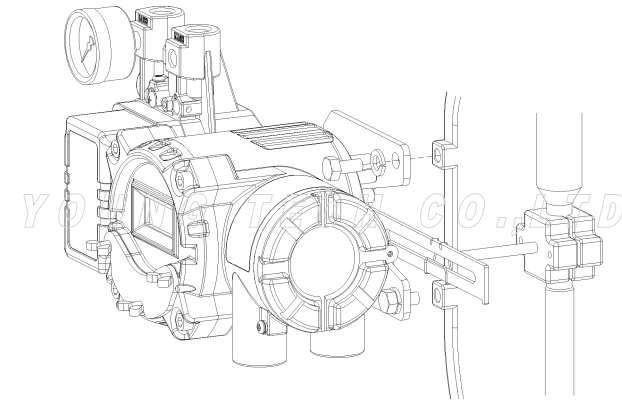

Installation of actuator clamp and connection bar

5. Connect air filter regulator with the actuator temporarily. Set supply pressure of air filter regulator in order that actuator clamp is positioned at 50% of valve stroke.

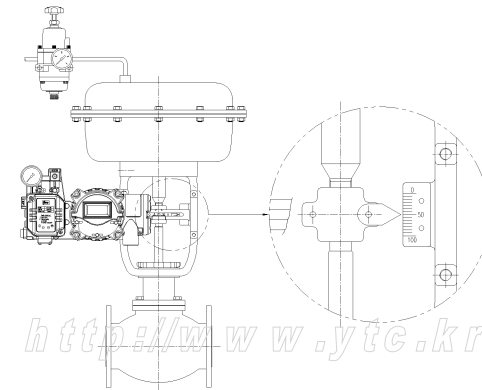

Connection of supply pressure pipe between actuator and air filter regulator

6. Insert connection bar attached on actuator clamp into the slot of YT-2400L feedback lever. Ensure that inserting should be the following picture in order to reduce hysteresis.

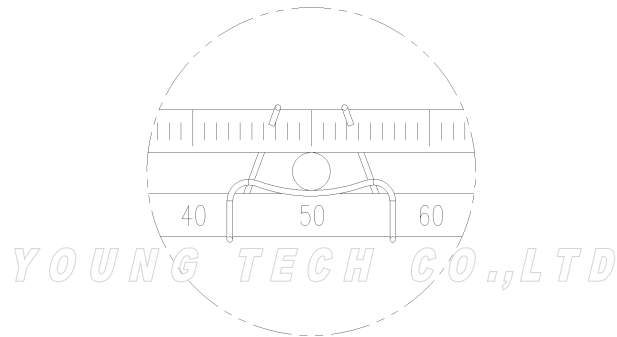

The connection bar inserted correctly between feedback lever and lever spring

7. Check if YT-2400L feedback lever is level at 50% of valve stroke. If not, make it be level with moving bracket or feedback link bar. If YT-2400 is installed not being level at 50% of valve stroke, product linearity becomes worse.

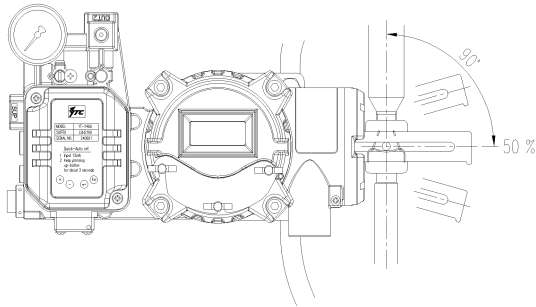

Feedback lever being leveled correctly

<http://www.ytc.kr>

8. Check valve stroke. The numbers indicating stroke are carved on the YT-2400L feedback lever. Set connection bar attached on actuator clamp on the number on feedback lever applicable to valve stroke as the following picture. To set the connection bar and the number, move the bracket attached on YT-2400L or connection bar from side to side.

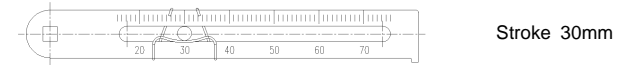

Stroke 30mm

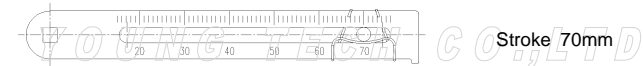

Stroke 70mm

Installation position of connection bar for valve stroke

Note

After installation, operate valve from 0 stroke to 100% stroke with using air filter regulator on the actuator. When the stroke is both 0% and 100%, feedback lever should not be reached to the lever stopper on the backside of YT-2400. If feedback lever reaches to the lever stopper, move attachment position of YT-2400L to the direction becoming more distant from yoke center.

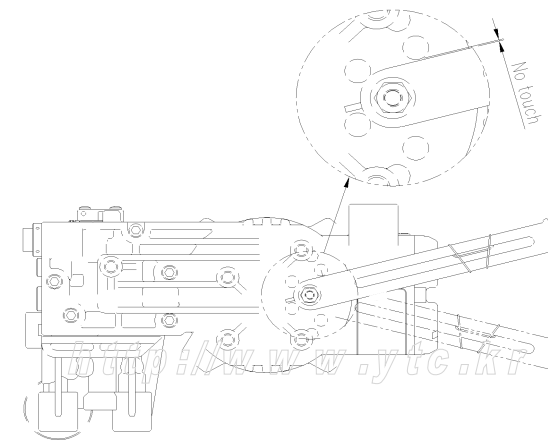

Check whether or not lever stopper and feedback lever is contacted

9. If YT-2400L is installed accurately as above procedures, lock the bolts and nuts of bracket and feedback lever connection bar completely.

YT-2400R installation

YT-2400R is used for rotary motion valve such as ball valve or butterfly valve using rack and pinion, scotch yoke or complex type actuator whose stem is rotated 90 degrees. YT-2400R consists of the following components.

1. YT-2400R main body
2. Fork lever and lever spring to attach on actuator
3. 1 set of bracket
4. 4pcs of Hexagon head bolt M8x1.25P
5. 4pcs of M8 plate washer

YT-2400R installation example

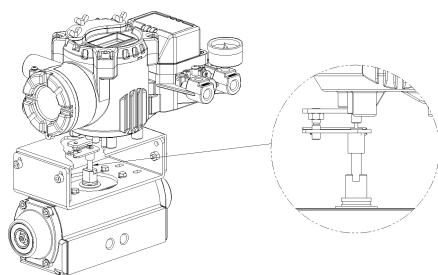

YT-2400R installation example of fork lever

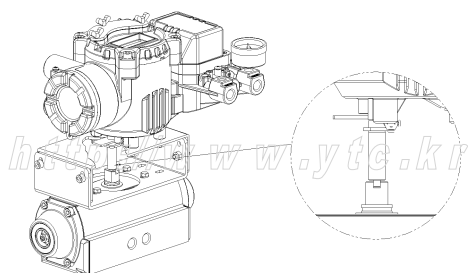

YT-2400R installation example of Namur shaft

Installing YT-2400R with bracket

YT-2400R is supplied with standard bracket. The bracket is consists of 2 part and can be used with Fork lever and Namur shaft. The bracket is assembled in the factory as based on 20mm of actuator stem height. But if actuator stem height is higher than that like 30mm, 50mm, reassemble the bracket adjusting to the height. Referring to the following table, check the hole positions.

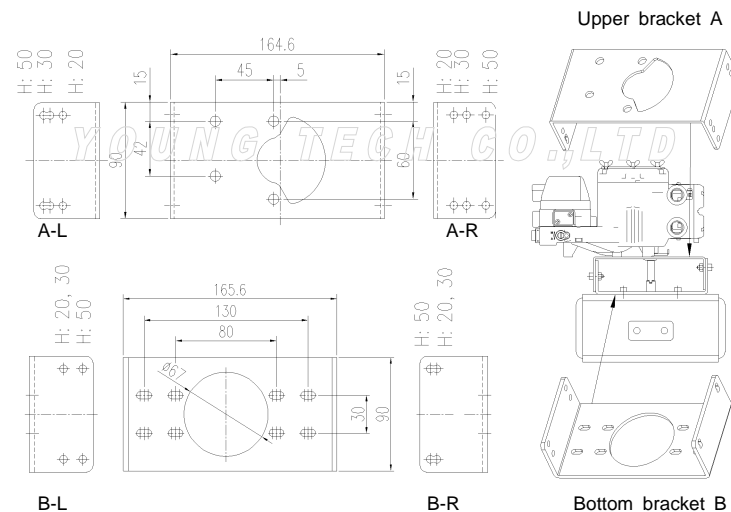

Bracket assembly method by actuator stem height H

Actuator stem height (H)	Markings of bolt holes			
	A-L	B-L	A-R	B-R
20mm	H : 20	H : 20, 30	H : 20	H : 20, 30
30mm	H : 30	H : 20, 30	H : 30	H : 20, 30
50mm	H : 50	H : 50	H : 50	H : 50

Ex) In case that H is 30mm, A-L should be locked in H:30 hole and B-L in H:20,30, A-R in H:30, B-R in H:20,30 with bolts.

<http://www.ytc.kr>

1. Usual types of actuator stem height (H) are 20, 30 and 50mm. After checking H, assemble brackets as explained on the previous page. The bracket is set as 20mm type in the factory.

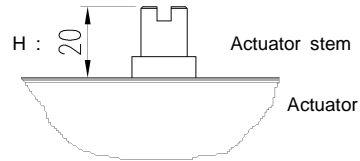

Actuator stem height (H=20mm)

2. Attach bracket to the actuator using hexagon head bolts or wrench bolts. Diameter of bracket bolt holes is 6mm. Use spring washers or any other equipment so as the bolts not to be loosened by vibration or impact. The direction of bracket is different by operating conditions, but normal direction is as following picture. That is, when the piping of actuator and YT-2400R is direction A, bracket hole and indicator attached on the bottom of YT-2400R main shaft should be same direction as being half circle.

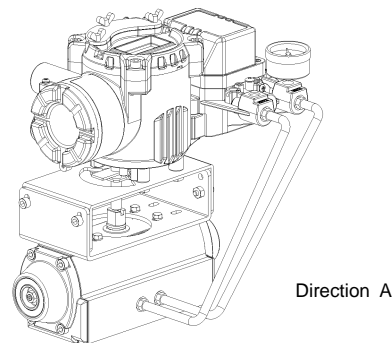

Attachment direction of bracket and actuator

3. Set rotation position of actuator stem as initial zero point which is stroke 0%. In case of spring return type single actuator, since the actuator stem is always rotated at zero point without supply pressure, it is easy to check zero point. If the actuator is double acting, check that whether it is clockwise or counter clockwise or the rotation direction of actuator stem with using supply pressure.

4. Set actuator stem as initial zero point and install fork lever as the following picture. Ensure the position of initial zero point when actuator stem is clockwise or counter clockwise. Installation angle of fork lever should be about 45 degree based on the linear shaft. But the angle is not related to Namur shaft.

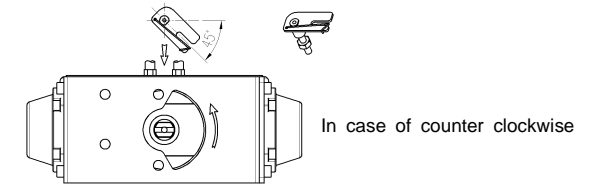

YOUNG TESH CO., LTD

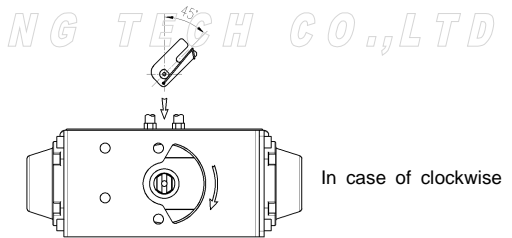

Installation position of fork lever

5. If the fork lever position is set, lock check nuts assembled on the bottom of fork lever with turning clockwise. Set the upper height of fork lever as 6-11mm lower than bracket upper height.

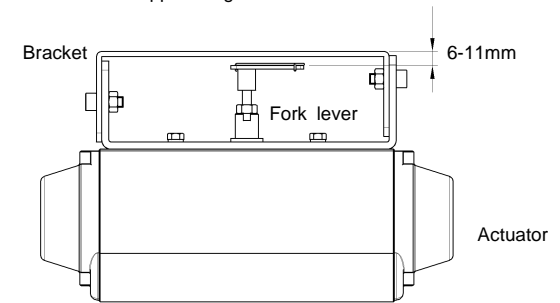

Height of bracket, fork and fork lever

<http://www.ytc.kr>

6. Attach YT-2400R to the bracket. Fix the clamping pin on the main shaft center of YT-2400R into the hole of fork lever and insert connection bar attached on the main shaft lever into fork lever slot to be locked fork lever spring. This is to fit the main shaft of YT-2400R and the center of actuator stem. If they are not fitted, product durability is getting worse due to too much force on the main shaft of YT-2400.

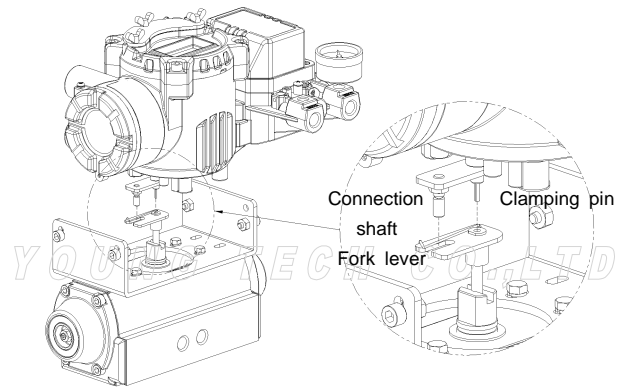

Fitting the pin on the YT-2400R main shaft into fork lever hole

7. Fix YT-2400R base and the bracket with hexagon head bolts and plate washer. It is better to lock the bracket and YT-2400R after checking the position of YT-2400R inserting four bolts.

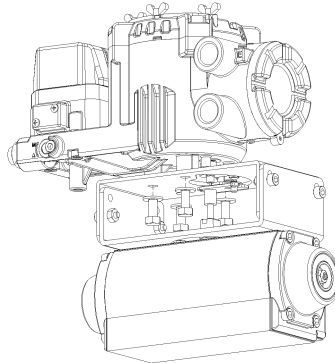

Assembly status of YT-2400R

<http://www.ytc.kr>

Piping connection

Note

1. To prevent moisture, oil and dust from being led into the product, give careful consideration to the choice of supply pressure compressor and its system.
2. We recommend to attach filter or air filter regulator in front of supply port of YT-2400.

Conditions of supply pressure

1. Dry air whose dew point is at least 10℃ lower than that of ambient temperature.
2. Be free from solid particles as a result of being passed through 5 μ m or finer filter.
3. Not contain oil or lubricating oil.
4. Comply with ANSI/ISA-57.3 1975(R1981) or ISA S7.3-1975(R1981).
5. Not used beyond the range of 1.4 - 7 kgf/cm² (140 - 700 kPa).
6. Set supply pressure of air filter regulator as 10% higher than operating pressure of actuator of spring range pressure.

Conditions of pipe

1. Remove foreign objects inside of pipe.
2. Do not use squeezed or broken pipe.
3. To maintain flow rate of YT-2400, use the pipe whose inner diameter is more than 6mm (outer diameter 10mm).
4. Do not connect the pipe too long. It affects flow rate due to the friction inside the pipe.

Piping connection with actuator

Single acting actuator

YT-2400 series single acting type is set to use OUT1 port. Therefore, in case of using single acting type of spring return actuator, OUT1 port should be connected with supply pressure port of actuator.

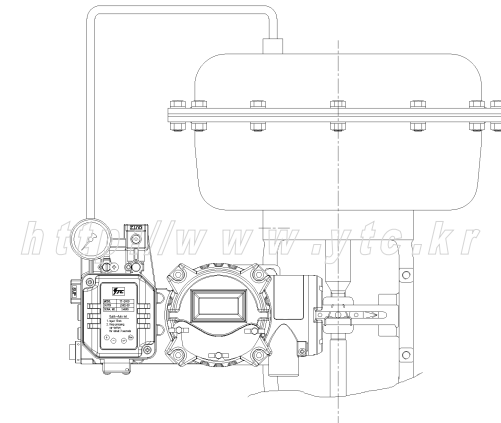

Piping connection example of YT-2400L with single acting actuator

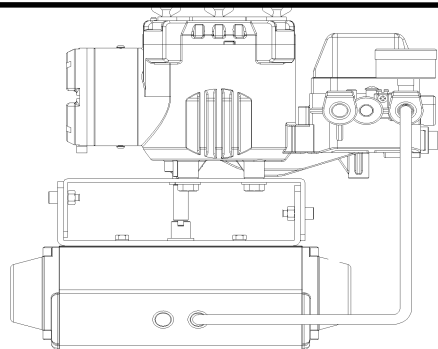

Piping connection example of YT-2400R with single acting actuator

Double acting actuator

In case of YT-2400 series double acting type, when input current signal, supply pressure is out from OUT1 port.

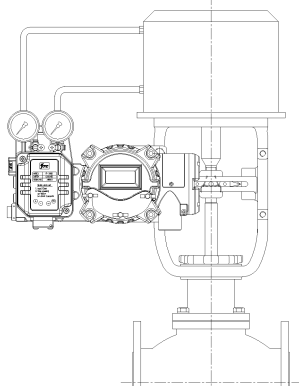

Piping connection example of YT-2400L with double acting actuator

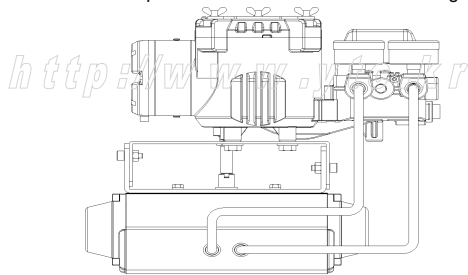

Piping connection example of YT-2400R with double acting actuator

Power connection

Note

1. In hazardous area like explosive gas area, conduit tube or pressure-proof packing union must be used. In case of pressure-proof packing union, use the cable that has appropriate outer diameter considering inner rubber packing size. And in case of conduit tube, ensure to be fully sealed with using gasket or sealing materials..

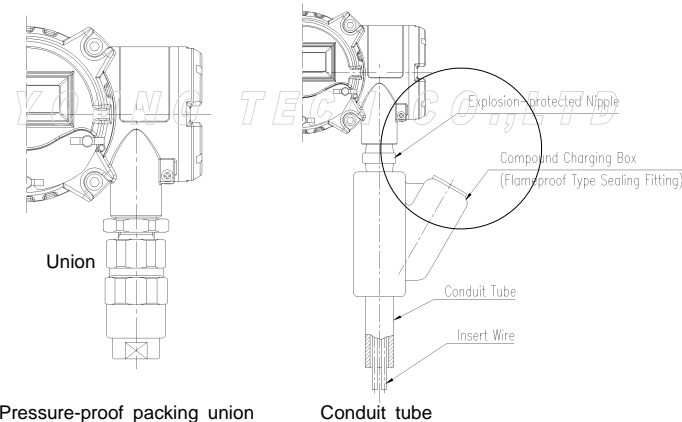

2. Conduit entry size is PF 1/2 or G 1/2.
3. When the power is connected, do not open the cover of the part that the power is connected like terminal or PCB. Confirm if the power is shut down before open the cover. When open the cover, the current or voltage must not be remained after power is shut down.
4. Use ring type rug to protect from vibration, impact and tension.
5. If the position transmitter or limit switch is installed, DC 10-28V or DC 12-24V power should be additionally supplied each. But ensure not to exceed maximum DC 30V.
6. For product protection, ground with ground terminal on terminal box or PCB plate.
7. Use ring type wire terminal to prevent vibration or impact.
8. Do not install the cable near the equipment such as high-capacity transformer or motor generating noise.
9. Use shielded cable against noise.

Terminal connection of current input signal

1. Loosen locking bolts of terminal box cover with 3mm wrench.
2. Open the cover turning to counter-clockwise with grabbing terminal box cover or using driver head.
3. There are two entries on the right bottom of YT-2400. When connecting power, pressure-roof packing union or conduit tube can be used. Choose suitable connection type considering explosion proof and installation conditions and insert cable to terminal part.
4. Terminal of current input signal is on the left bottom of entire terminal plate as following picture. Insert terminal bolts in cable terminal holes and lock them with + terminal and - terminal each on terminal plate. Refer to the following. Tighten terminal bolts with 1.5N.m (15kg.cm) torque.
5. Ensure not to change the polarity of terminal.
6. Set the terminal box cover with terminal box and turn to clockwise until the bolts are locked completely.
7. Lock the locking bolts of terminal box cover to clockwise with using 3mm wrench.

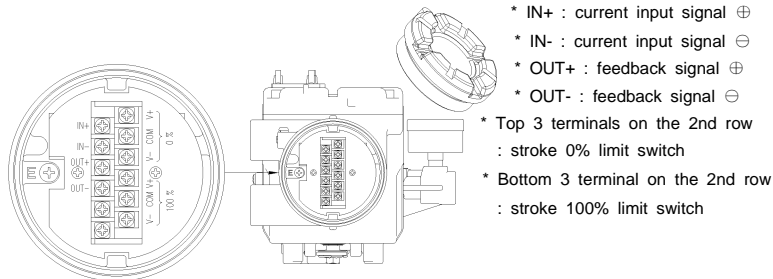

Terminal plate position

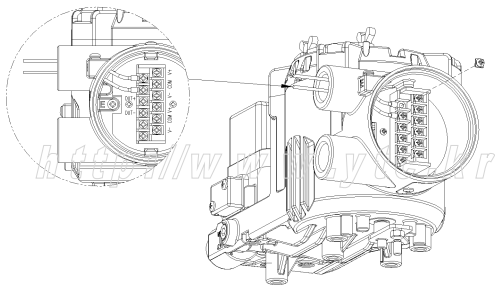

Connection position of current input signal terminal

Terminal connection of feedback signal

1. Loosen locking bolts of terminal box cover with using 3mm wrench.
2. Open the cover turning to counter-clockwise with grabbing terminal box cover or using driver head.
3. There are two entries on the right bottom of YT-2400. When connecting power, pressure-roof packing union or conduit tube can be used. Choose suitable connection type considering explosion proof and installation conditions and insert cable to terminal part.
4. Terminal of current input signal is on the left bottom of entire terminal plate as following picture. Insert terminal bolts in cable terminal holes and lock them with + terminal and - terminal each on terminal plate. Refer to the following. Tighten terminal bolts with 1.5N.m (15kg.cm) torque.
5. Ensure not to change the polarity of terminal.
6. Set the terminal box cover with terminal box and turn to clockwise until the bolts are locked completely.
7. Lock the locking bolts of terminal box cover to clockwise with using 3mm wrench.

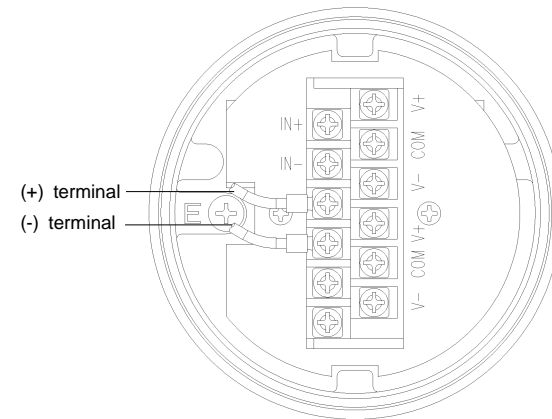

<http://www.ytc.kr>

Terminal connection of transmitter

Terminal connection of limit switch

1. Loosen locking bolts of terminal box cover with using 3mm wrench.
2. Open the cover turning to counter-clockwise with grabbing terminal box cover or using driver head.
3. There are two entries on the right bottom of YT-2400. When connecting power, pressure-roof packing union or conduit tube can be used. Choose suitable connection type considering explosion proof and installation conditions and insert cable to terminal part.
4. Limit switch terminals are at the top of the terminal plate as following picture. Top three terminals on the right is valve's 0% position and three terminals on the bottom is valve's 100% position. Insert terminal bolts into cable ring terminal holes and lock them with + terminal and - terminal each on terminal plate. Tighten terminal bolts with 1.5N.m (15kg.cm) torque.
5. Ensure not to change the polarity of terminal.
6. Set the terminal box cover with terminal box and turn to clockwise until the bolts are locked completely.
7. Lock the locking bolts of terminal box cover to clockwise with using 3mm wrench.
8. The adjustment of RA or DA is available with moving deep switch on the right of the terminal plate.

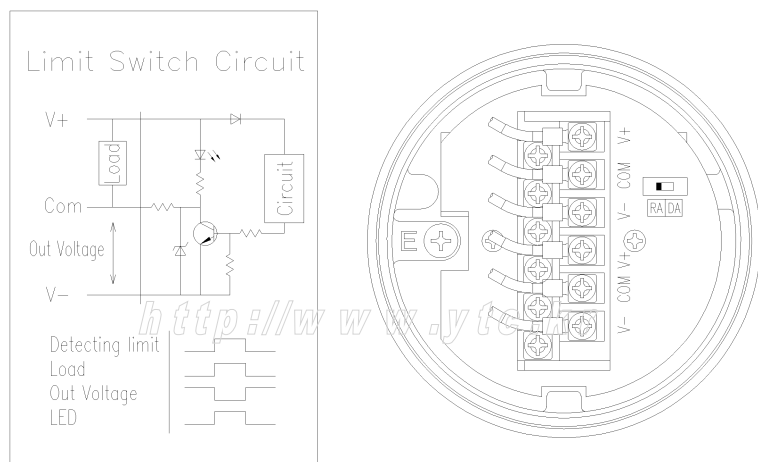

Terminal connection of limit switch

Terminal connection for ground

1. The ground is necessary for the safety of YT-2400 series and system.
2. There are inside terminal on the right bottom of the terminal plate and outside terminal beside outer cable entry. Using any ground terminal is available and resistance must be less than 100 ohm.
3. When using outside ground, loosen ground bolts with + driver. Insert outside ground bolts and spring washer into ring type terminal of the cable ground and tighten them with bolts.
4. When using inside ground, loosen locking bolts of terminal box cover with using 3mm wrench.
5. Open the cover turning to counter-clockwise with grabbing terminal box cover or using driver head.
6. There are two entries on the right bottom of YT-2400. When connecting power, pressure-roof packing union or conduit tube can be used. Choose suitable connection type considering explosion proof and installation conditions and insert cable ground into terminal box.
7. Inside ground terminals are at the bottom of the terminal plate as following picture. There are two terminals on the right, each terminal can be used. Insert terminal bolts into the ring terminal holes of cable ground and lock them as follows. Tighten terminal bolts with 1.5N.m (15kg.cm) torque.
8. Lock the locking bolts of terminal box cover to clockwise with using 3mm wrench.

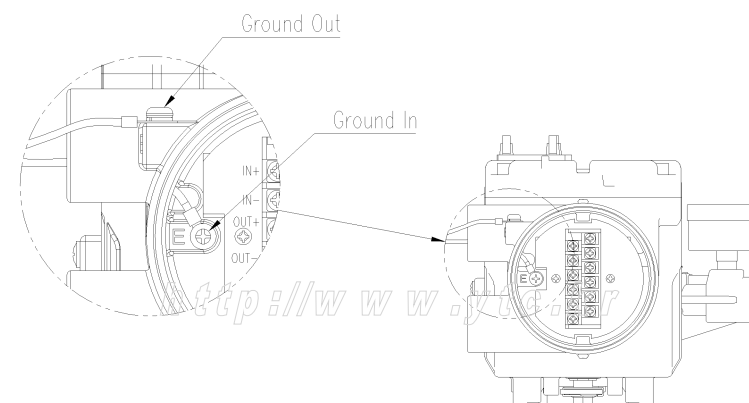

Ground terminal connection

A/M switch (Auto/Manual switch)

There is A/M switch on the bottom of YT-2400. If this switch is set as auto, supply pressure is transmitted to actuator by the operation of YT-2400 and if it is set as manual, supply pressure of air filter regulator is transmitted to actuator regardless of YT-2400.

* When A/M switch is set as manual, ensure that too much pressure must not be transmitted to the actuator.

1. Check if the supply pressure of air filter regulator is too high.
2. Turn the switch clockwise and supply pressure of air filter regulator is transmitted to actuator.
3. If turn the switch counter-clockwise, YT-2400 is operated normally.

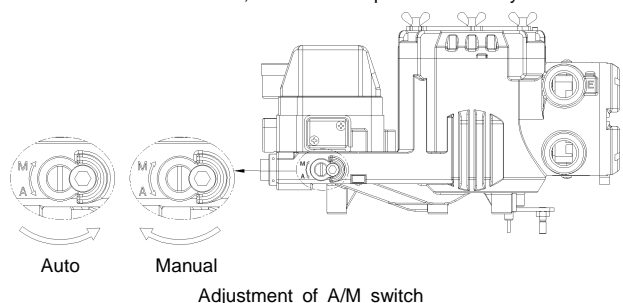

Variable orifice

The actuator volume is too small, hunting can be occurred. In this case, adjust variable orifice with using (-) driver, then hunting is prevented by reducing flow rate of supply pressure transmitting to actuator.

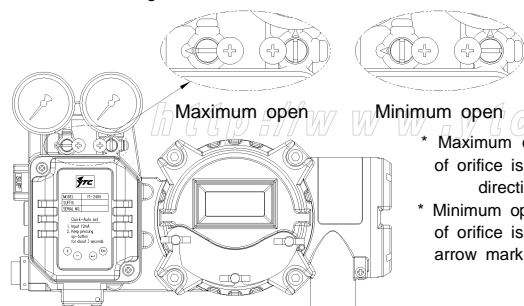

Adjustment of variable orifice

- * Maximum open : The direction of - driver of orifice is in accordance with the direction of arrow mark below gauge.
- * Minimum open : The direction of - driver of orifice is 90 degree with the direction of arrow mark below gauge.

Auto calibration and Basic operations

Warning : Since this makes valve or actuator move, before auto calibration valve must be separated from entire system.

Button

YT-2400 Series perform various functions with using four buttons. The shape and position of buttons are as follows.

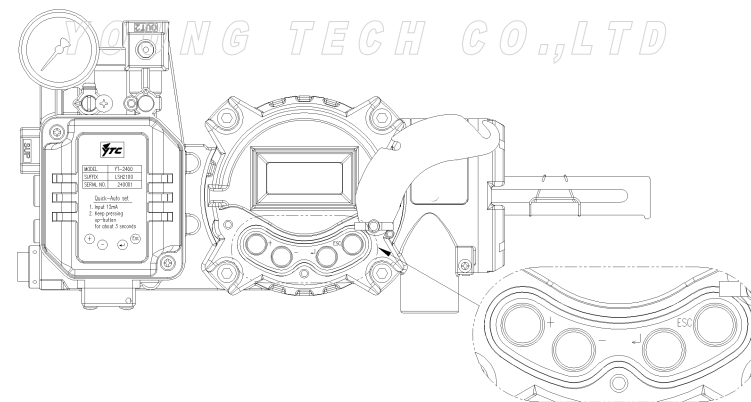

The buttons of YT-2400

- <ESC> : It is used to return to previous menu.
- <Enter> : It is used to go to Main menu, save adjusted parameter values or choose sub menus.
- <DOWN> : It is used to move to another menu or change parameter values.
- <UP> : It is used to move to another menu or change parameter values.

<http://www.ytc.kr>

RUN Mode

After connect power to YT-2400, the following is displayed on LCD in 6 seconds.

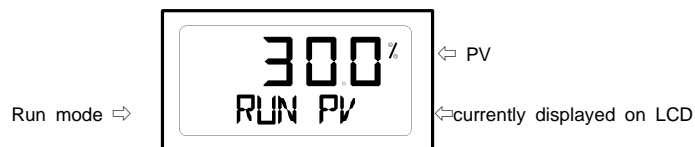

Run on the bottom line means that YT-2400 adjust valve stroke with receiving outside signal (4-20mA) and PV means the number on the LCD. In RUN mode, valve stroke is changed according to input signal. There are six types displayed in Run mode.

①	Run PV	Process Value	Valve stroke (%)
②	Run SV %	Set Value	Input signal (0 - 100%)
③	Run SV mA	Set Value	Input signal (4 - 20mA)
④	Run MV	Manipulate Value	Motor controlled variable (Digit)
⑤	Run Vel	Velocity	Current valve speed (Digit)
⑥	Run Err	Error	Difference between SV and PV (%)

In order to change display, push <ESC> and <UP> at same time. Whenever push the button, display is changed in order. If push <ESC> and <DOWN> simultaneously, the order is opposite and if push only <ESC>, display is returned to RUN mode.

First auto calibration

First auto calibration is usually used when YT-2400 has not been set, such as the occasion of initial setting with valve at valve company or replacement with other product in the field. In this case, entire parameters are set by using AUTO2 calibration.

Warning : When YT-2400 is installed on the valve in the field after setting, we recommend to use 'AUTO1 calibration' than AUTO2 calibration. Because optimum parameters are set by valve company, it is better that those registered parameters are not changed by AUTO1 calibration.

- (1) Connect power. Any values between 4 to 20mA (DC) can be used for power. After connecting power 'READY 6, 5, 4, 3, 2, 1' message is appeared in order on LCD, which means preparing time to operate PCB circuit and parts. The following message is displayed in 6 seconds. Push <ENTER> for 6 seconds at **RUN** mode and **AUTO CAL** message is appeared.
- (2) Push <ENTER> and then **AUTO1** mode is started.
- (3) Push <DOWN> and **AUTO2** mode is displayed.
- (4) Push <ENTER> at **AUTO2** mode. Auto 2 calibration is started and the next modes are displayed in order on LCD. Normally it takes 3-5 minutes for auto calibration in **AUTO2** mode but it can be different by actuator's volume and other conditions.
- (4) When Auto calibration is done, '**COMPLETE**' message is appeared on LCD. After 4 seconds the procedure is returned to **RUN** mode and valve stroke by current input signal is displayed as percentage.
- (5) Zero, Span, PID parameters and RA/DA are automatically set when Auto 2 calibration is completed.

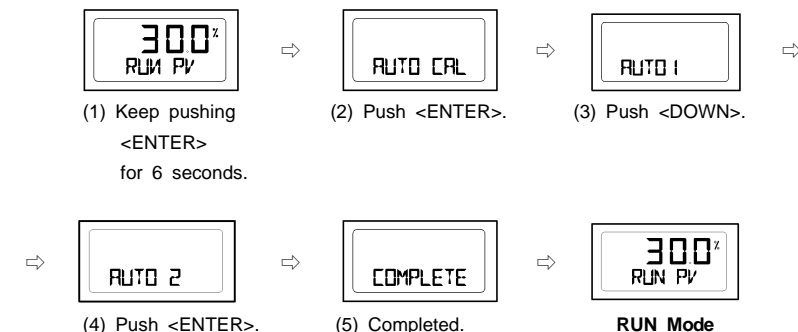

Entire modes and functions

Auto calibration (AUTO CAL)

The calibration of YT-2400 is simply performed by Auto calibration and there are 5 types of Auto calibration as AUTO1, AUTO2, AUTO3, BIAS, V_0.

AUTO1 calibration is useful for users' in the field and AUTO2 calibration is for valve company or initial parameters setting of YT-2400.

It takes about 2-3 minutes for auto calibration and it can be different by actuator's volume. AUTO1, AUTO2 and AUTO3 calibration set RA/DA automatically.

	Zero POINT	END POINT	KP, KI KD	BIAS	V_0	RA / DA
AUTO1	○	○	×	○	○	○
AUTO2	○	○	○	○	○	○
AUTO3	×	×	○	○	○	○
BIAS	×	×	×	×	×	×
V_0	×	×	×	×	○	×

Auto calibration types

Auto 1 calibration (AUTO1)

At this mode all parameters necessary to valve operation are set except KP, KI, KD. It is used to re-execute calibration by users in the field after being supplied YT-2400 whose parameters were all set by valve company.

- (1) Push <ENTER> for 6 seconds at **RUN** mode and **AUTO CAL** message is appeared.
- (2) Push <ENTER> and then **AUTO1** mode is displayed.
- (3) Push <ENTER> again at **AUTO1** mode and Auto1 calibration is started.
- (4) When Auto calibration is done, '**COMPLETE**' message is appeared on LCD. After 4 seconds the procedure is returned to **RUN** mode and valve stroke by current input signal is displayed as percentage.



- (1) Keep pushing <ENTER> for 6 seconds.



- (2) Push <ENTER>.



- (3) Push <ENTER>.



- (4) Completed.



- (5) Return to RUN mode after 4 seconds.

Auto 2 calibration (AUTO2)

All parameters necessary to operate valve are set. This calibration is used when YT-2400 is first installed with valve. Refer to the chapter of first auto calibration.

Auto 3 calibration (AUTO3)

All parameters necessary to operate valve are set except zero and end point. This function is used to re-execute auto calibration without changing zero and end point after adjusting them manually.

- (1) Push <DOWN> at AUTO2 and AUTO3 is displayed.

(2) Push <ENTER> and AUTO3 calibration is started. The next procedure of this calibration is as same as other calibrations.

BIAS calibration

BIAS means standard value of motor control that is used in positioner. It is affected by supply pressure, KP and other values and therefore it should be re-adjusted if supply pressure or KP is changed. Unless this value is correctly set, accuracy can be very low.

- (1) Push <DOWN> at AUTO3 mode and BIAS mode is displayed.
- (2) Push <ENTER> and BIAS calibration is started. The next procedure of this calibration is as same as other calibrations.

Velocity calibration (V_0)

This is the function to find the standard value to recognize accurate valve speed. Unless this value is correctly set, KI control can be slower or impossible. In order to check if this value is accurately set, push <ESC> at RUN mode and RUN Vel is displayed. At this time the number on the bottom line on LCD indicates the value close to zero. (After valve is stopped) Usually the number is between -2 to 2. If the number is over 5, execute this function again and reset V_0 value.

- (1) Push <DOWN> at BIAS mode and V_0 mode is displayed.
- (2) Push <ENTER> and V_0 calibration is started. The next procedure of this calibration is as same as other calibrations.

Manual Mode

Manual mode is used to raise or lower the valve stem manually. At this mode valve stroke is adjusted by only operating buttons not by current input signal. This mode doesn't affect controlling data registered in YT-2400 and only makes to move valve stem up and down.

- (1) Keep pushing <ENTER> at RUN mode and AUTO CAL message is displayed.
- (2) Push <DOWN> and MANUAL mode is displayed.
- (3) Push <ENTER> again. Two lines on LCD are appeared. The upper one indicates valve stroke by percentage and the lower one indicates absolute value of inner resistance of YT-2400. *MA means that Manual mode is in operation.
- (4) Push <UP> or <DOWN> and valve stem moves up or down. Regardless of RA/DA, if push <UP>, valve stem moves up (in case of linear valve) and if push <DOWN>, valve stem moves down. In order to make the valve stem move fast, push <ENTER> with <UP>, <DOWN>.

Push <UP>.	Valve stem is up slowly.
Push <UP> + <ENTER> at the same time.	Valve stem is up quickly.
Push <DOWN>.	Valve stem is down slowly.
Push <DOWN>+<ENTER> at the same time.	Valve stem is down quickly.

Button operation for valve stem movement

- (5) Push <ESC> and MANUAL mode is displayed.

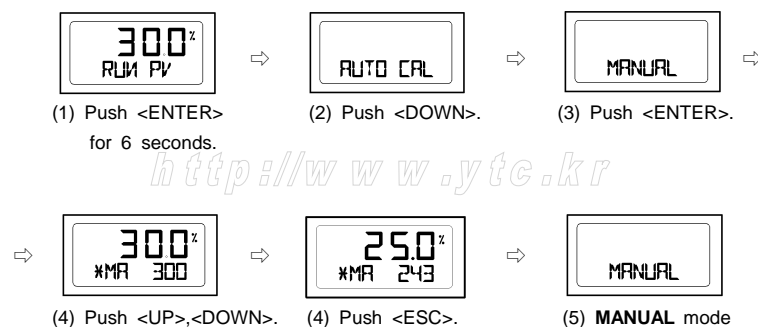

Parameter mode (PARAM)

With auto calibration, optimum operation is available for almost every valve actuator's control. But if the optimum operation is difficult because of hunting or oscillation, it can be solved by PID parameters and DeadZone.

Parameter types

There are four types in parameter of Dead Zone, KP, KI, KD. These values are reflected as soon as they are changed, therefore the appropriate values are found with checking valve's motion by real time.

Dead Zone (dEAdZONE)

This is the section of Error % that I control is not operated. If there are hunting or oscillation continuously due to the friction between stem and packing, they are prevented with this parameter.

KP

This is proportion constant value of correction that is correcting by Error %. If this value is too big, there can be hunting though it finds position by input signal. If the value is too small, accuracy gets worse.

KI

This is integral constant value adding or subtracting the correction that is correcting by Error % on previous correction signal. If this value is too big, there can be oscillation. If it is too small, the time to find the exact position gets longer.

KD

This is differential constant value adding previous correction signal with changing correction signal by Error % change rate. If this value is too big, there can be hunting. If it is too small, dynamic characteristic during the time to find the position gets worse.

Adjustment of Parameter

Dead zone (dEAdZONE)

- (1) Push <ENTER> at RUN mode for 6 seconds and AUTO CAL message is appeared.
- (2) Push <DOWN> twice and PARAM mode is displayed.
- (3) Push <ENTER> and dEAdZONE mode is displayed.
- (4) Push <ENTER> again and *EAdZONE message is appeared.
- (5) Adjust dEAdZONE value by <UP> or <DOWN>. Adjusted value is applied right away without additional operation, so users can easily check its adjustment by changing current

input signal to YT-2400. It means that optimum control value is found by adjusting values during valve operation.

(6) Push <ENTER> to save the value. +EAdZONE message is on LCD.

(7) Push <ESC> three times to return to RUN mode.



(1) Push <ENTER> for 6 seconds. (2) Push <DOWN> twice. (3) Push <ENTER>.

YOUNG TECH CO.,LTD

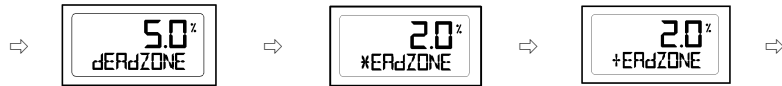

(4) Push <ENTER>. (5) Push <ENTER> after adjustment by <UP>, <DOWN>. (6) Push <ESC>.



(7) Push <ESC> twice. RUN Mode

KP

(1)-(3) Adjustment method and procedure is as same as dEAdZONE.

(4) Push <DOWN> at dEAdZONE mode and KP mode is displayed.

(5) Push <ENTER> and *KP message is on LCD.

(6) Adjust KP values with <UP> or <DOWN>. Adjusted value is applied right away without additional operation, so users can easily check its adjustment by changing current input signal to YT-2400. It means that optimum control value is found by adjusting values during valve operation.

(7) Push <ENTER> to save the value. +KP message is on LCD.

(8) Push <ESC>.

(9) Push <ESC> twice to return to RUN mode.



(1) Push <ENTER> for 6 seconds. (2) Push <DOWN> twice. (3) Push <ENTER>.

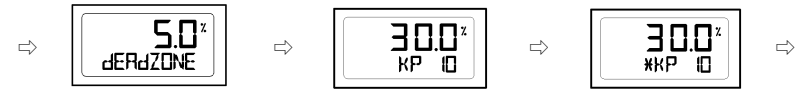

(4) Push <DOWN>. (5) Push <ENTER>. (6) Push <ENTER> after adjustment with <UP>,<DOWN>.



(7) Push <ESC>. (8) Push <ESC> twice. RUN Mode

KI

(1)-(3) Adjustment method and procedure is as same as dEAdZONE.

(4) Push <DOWN> twice at dEAdZONE mode, then KI mode is displayed.

(5) Push <ENTER> at KI mode and *KI message is appeared on LCD.

(6) Adjust KI value with <UP> or <DOWN>. Adjusted value is applied at once without additional operation, so users can easily check its adjustment by changing current input signal to YT-2400. It means that optimum control value is found by adjusting values during valve operation. Push <ENTER> to save the value and +KI message is on LCD.

(7) Push <ESC>.

(8) Push <ESC> twice to return to RUN mode.



(1) Push <ENTER> for 6 seconds. (2) Push <DOWN> twice. (3) Push <ENTER>.

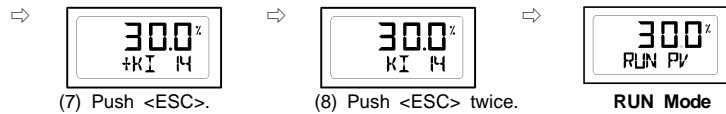

(4) Push <DOWN> twice. (5) Push <ENTER>. (6) Push <ENTER> after adjustment with <UP>,<DOWN>.

**Kd**

- (1)-(3) Adjustment method and procedure is as same as dEAdZONE.
- (4) Push <DOWN> three times at dEAdZONE mode, then Kd mode is displayed.
- (5) Push <ENTER> at Kd mode and *Kd message is appeared on LCD.
- (6) Adjust Kd value with <UP> or <DOWN>. Adjusted value is applied at once without additional operation, so users can easily check its adjustment by changing current input signal to YT-2400. It means that optimum control value is found by adjusting values during valve operation. Push <ENTER> to save the value and +Kd message is on LCD.
- (7) Push <ESC>.
- (8) Push <ESC> twice to return to RUN mode.

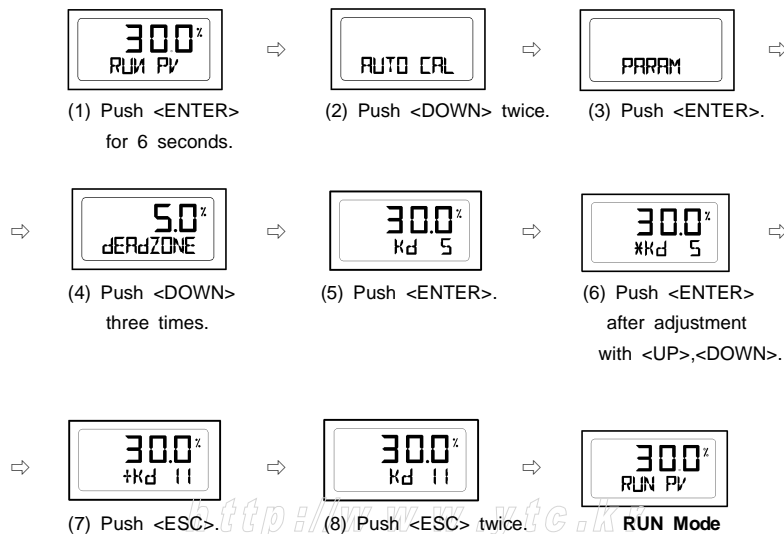
**HAND CAL**

When auto calibration is started, YT-2400 sets zero point and end point based on full stroke. But when there is necessity of re-adjusting zero and end point to use specific section in entire stroke, Hand calibration is used. Both valve and transmitter can be re-adjusted.

Hand calibration types

- PV_ZERO : Edit mode to change the zero point of valve.
- PV_END : Edit mode to change the end point of valve.
- TR-ZERO : Edit mode to change the zero point of transmitter.
- TR_END : Edit mode to change the end point of transmitter.

Adjustment of valve zero point ((1)-(5)) and end point ((6)-(10))

- (1) Push <ENTER> at RUN mode for six seconds and then AUTO CAL mode is displayed. Push <DOWN> three times, then HAND CAL mode is displayed.
- (2) Push <ENTER> at HAND CAL mode and PV_ZERO mode is started.
- (3) Push <ENTER> at PV_ZERO mode and *PZ mode is started. At this mode it is available to change valve zero point and valve stem moves automatically to current zero point. On LCD valve stroke is displayed as 0%. *PZ message indicating edit mode of zero point and inner value showing current zero point position are also displayed.
- (4) Adjust Valve stem with pushing <UP>, <DOWN>. When valve stem is arrived at desirable zero point, save it with <ENTER>. +PZ message is appeared on LCD.
- (5) Push <ESC> to return to PV_ZERO mode.
(Push <ESC> twice at this mode to return to RUN mode.)
- (6) In order to change valve end point, push <DOWN> at PV_ZERO mode and PV_END mode is started.
- (7) Push <ENTER> at PV_END mode and *PE mode is displayed. At this mode it is available to change valve end point and valve stem moves automatically to current end point. On LCD valve stroke is displayed as 100%. *PE message indicating edit mode of end point and inner value of end point are also displayed.
- (8) Adjust valve stem with using <UP> or <DOWN>. When valve stem is arrived at desirable end point, save it with <ENTER>. +PE message is appeared on LCD.
- (9) Push <ESC> to return to PV_END mode.
- (10) Push <ESC> twice and RUN mode is displayed.
(Push <DOWN> at PV_END mode to go to TR_ZERO mode.)

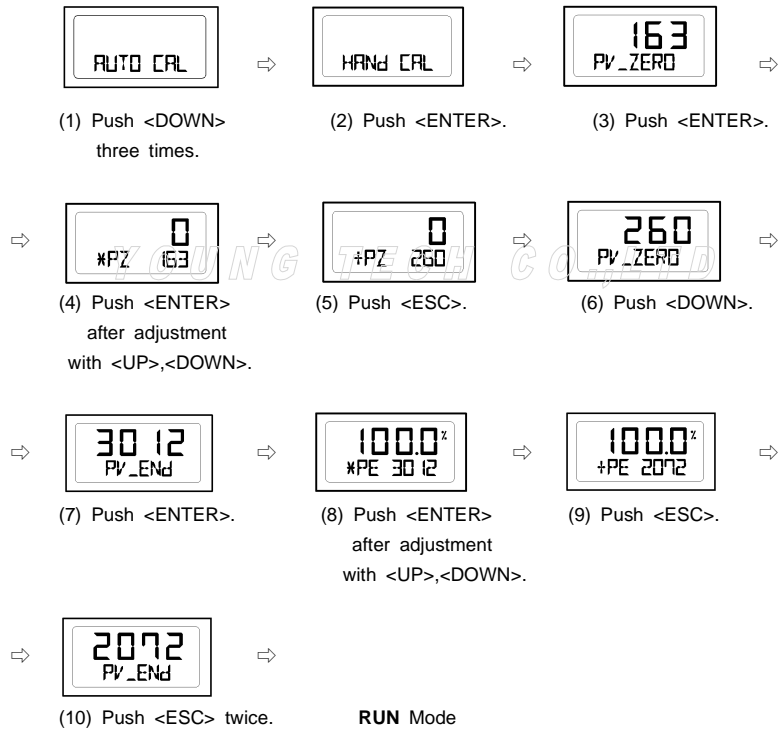

Adjustment of zero point ((1)~(4)), end point ((5)~(9)) of transmitter

If valve zero point and end point are changed, transmitter is also changed automatically. So usually there's no need that transmitter zero point and end point are adjusted by users, but if transmitter output signal is unstable, transmitter zero point and end point should be adjusted. The ammeter showing feedback signal is necessary and the connection should be done as following picture.

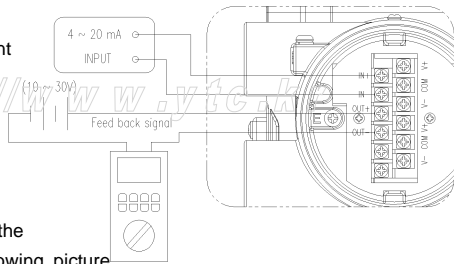

- (1) Push <DOWN> at PV_END mode and then TR_ZERO mode is displayed.
- (2) Push <ENTER>. *R_ZERO mode is started and at this mode users can adjust zero point of transmitter. Valve stem is moved to zero point automatically.
- (3) Push <UP> or <DOWN>. The number on the above on LCD is changed and measured current value is changed accordingly on ammeter equipped outside. Adjust it to be 4mA and push <ENTER> to save it. +R_ZERO message is appeared.
- (4) Push <ESC>. TR_ZERO mode is displayed.
- (5) Push <DOWN> at TR_ZERO mode. Then TR_END mode is displayed. (Push <ESC> twice to return to RUN Mode.)
- (6) Push <ENTER>. *TR_END mode is started and at this mode users can adjust end point of transmitter. Valve stem is moved to end point automatically.
- (7) Adjust measured current value to be 20mA on ammeter with <UP> or <DOWN>. Push <ENTER> to save it. +R_END message is appeared.
- (8) Push <ESC>. TR_END mode is displayed.
- (9) Push <ESC> twice at this mode to return to RUN mode.

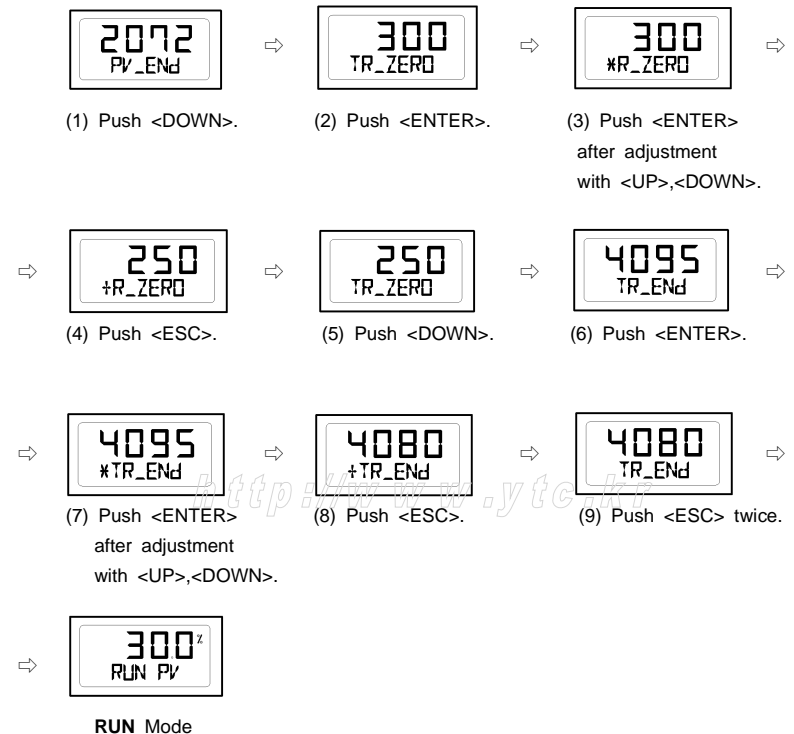

Valve mode

This mode is to adjust the various characteristics.

Action type (ACT)

It sets Direct Action (DA) and Reverse Action (RA).

Characteristics (CHAR)

It sets Characteristics. There are three types of valve characteristics, which are Linear (LIN), EQ% (EQ) and Quick Open (QO). The following is the example of three characteristics curves.

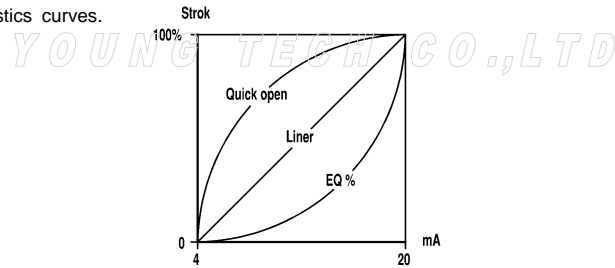

The example of three characteristic curves

User Characteristics (USER SET)

When specific characteristic which is not included in above characteristics is needed, it is available to make specific characteristic curve by choosing 16 points voluntarily according to field conditions and users' need.

Tight Shut Open (TSHUT OP)

This is to press down valve fully at any value around 20mA current input signal.

Tight Shut Close (TSHUT CL)

This is to close valve completely at setting value around 4mA input signal from outside.

Split Range Control (SPLIT)

This is to control entire stroke by three input signal of 4-20mA, 4-12mA and 12-20mA.

Adjustment of Acting type (ACT)

- (1) Push <ENTER> at RUN mode for six seconds and then AUTO CAL mode is displayed. Push <DOWN> four times to go into VALVE mode.
- (2) Push <ENTER> and ACT RA (in case of RA) is displayed.
- (3) Push <ENTER> again, then *ACT RA is displayed.
- (4) Adjust to *ACT DA with pushing <UP> or <DOWN> and save it with <ENTER>. +ACT DA message is on.

- (5) Push <ESC> three times to return to RUN mode.

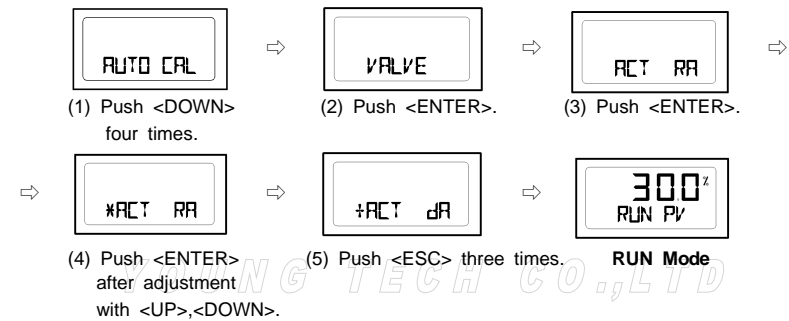

Adjustment of Characteristics (CHAR)

- (1) Push <ENTER> at VALVE mode and then push <DOWN>. CHAR LIN (in case of linear characteristics) mode is displayed.
- (2) Push <ENTER>. *HAR LIN mode is displayed and characteristics can be adjusted at this mode.
- (3) Adjust Characteristics (ex: EQ) with pushing <UP> or <DOWN> and save it with <ENTER>. +HAR EQ is displayed.
- (4) Push <ESC> three times to return to RUN mode.

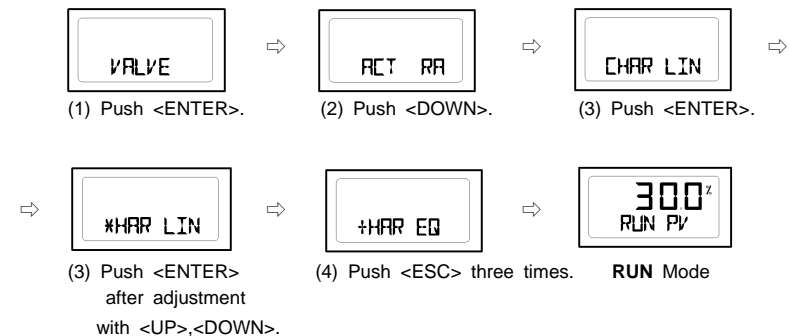

Adjustment of User Characteristics (USER SET)

- (1) Push <ENTER> at VALVE mode and ACT RA or ACT DA is displayed.
- (2) Push <DOWN> twice, then USER SET mode is started.
- (3) Push <ENTER>. *P0 SET mode is displayed and at this mode users can adjust the first point of characteristic in sixteen points. The number on LCD is valve stroke percentage set to P0.
- (4) Adjust valve stroke percentage with using <UP> or <DOWN>.

- (5) Save it with <ENTER>. While P0 value is being saved, *P1 SET mode is displayed.
- (6) *P1 SET mode is to adjust the second point of characteristic in sixteen points. Adjustment method is as same as *P0 SET mode.
- (7) Save valve stroke percentage from P2 to P15 in the same way.
- (8) After adjustment of valve stroke percentage at *P15 SET mode, save it with <ENTER>.
- (9) +SER SET is displayed. Total sixteen points of valve stroke percentage are all set. Push <ESC> three times to return to RUN mode.

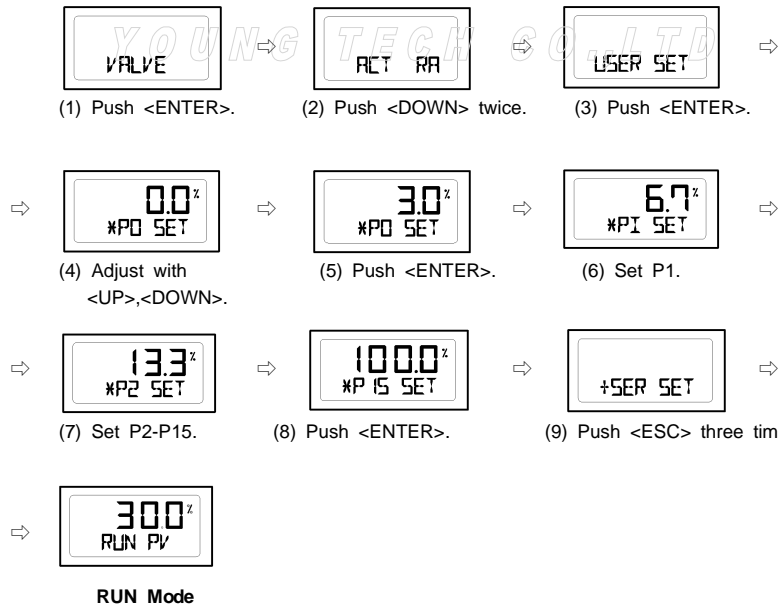

<http://www.ytc.kr>

Adjustment of Tight Shut Open (TSHUT OP)

- (1) Push <ENTER> at VALVE mode and ACT RA or ACT DA is displayed. Push <DOWN> three times at this mode, then TSHUT OP is displayed.
- (2) Push <ENTER>. *SHUT OP mode is displayed and in this mode users can set stroke at the time of Tight Open. Initial setting is done as 100%, which means cancellation of this function. Adjust the value (ex : 95.0%) with pushing <UP> or <DOWN> and save it with <ENTER>. +SHUT OP is displayed.
- (3) Push <ESC> three times to return to RUN mode.

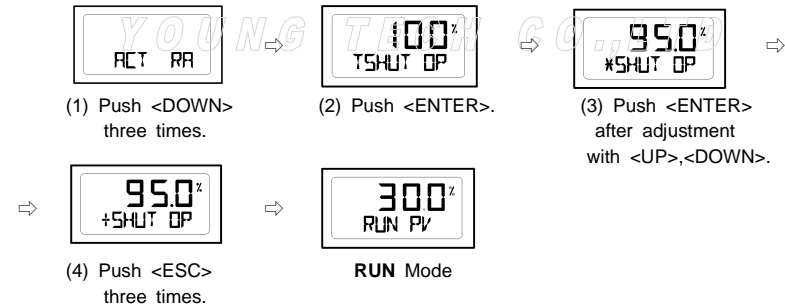

Adjustment of Tight Shut Close (TSHUT CL)

- (1) Push <ENTER> at VALVE mode and ACT RA or ACT DA is displayed. Push <DOWN> four times at this mode, then TSHUT CL is displayed.
- (2) Push <ENTER>. *SHUT CL mode is displayed and in this mode users can set stroke at the time of Tight Close. Initial setting is done as 0.3%. 0% means cancellation of this function. Adjust the value (ex : 0.5%) with pushing <UP> or <DOWN> and save it with <ENTER>. +SHUT CL is displayed.
- (3) Push <ESC> three times to return to RUN mode.

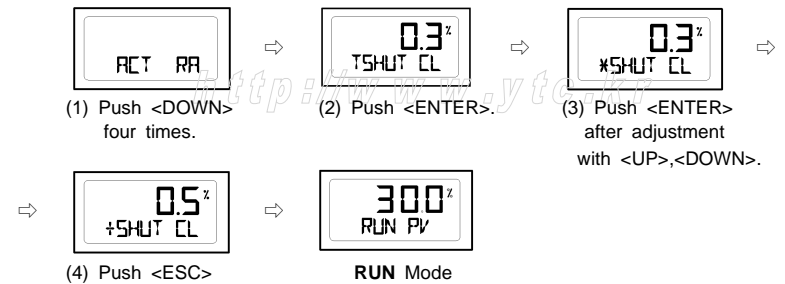

Adjustment of Split Range (SPLIT)

- (1) Push <ENTER> at VALVE mode and ACT RA or ACT DA is displayed.
- (2) Push <DOWN> five times and SPLIT mode is displayed. The numbers on LCD is the range of current signal input to YT-2400. 4-20mA current signal is set as standard.
- (3) Push <ENTER>. *SPLIT mode is displayed and input signal range can be adjusted. Adjust input signal range with <UP> or <DOWN> and save it with <ENTER>.
- (4) +SPLIT mode is displayed while saving adjusted range. Push <ESC> three times to return to RUN mode.

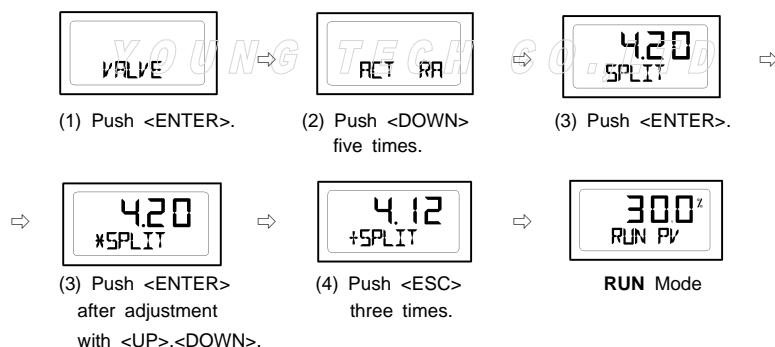

VIEW mode

This mode provides users with various information about YT-2400. And in this mode users can change valve stroke types displayed on LCD as % or numbers. Refer to the next table for information and description displayed on VIEW mode.

- (1) Push <DOWN> at AUTO CAL mode and VIEW mode is displayed.
- (2) Push <ENTER> at VIEW mode, then Information mode is started.
- (3) Check information with using <UP> or <DOWN> and push <ESC>.
- (4) Push <ESC> again to return to RUN mode.

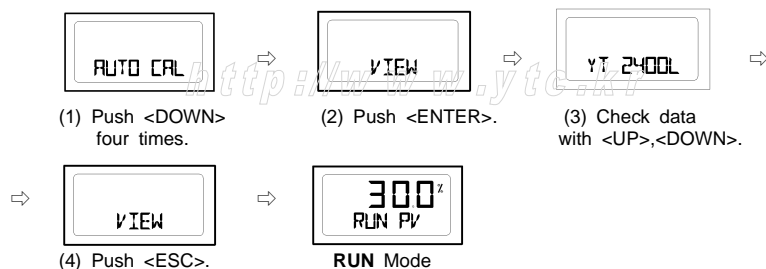

	Description
YT-2400L	Product model
VERSION	Main software version
HART V	Hart protocol version
POL Addr	Channel address used in Hart protocol
BIAS VI	BIAS value necessary to motor control (This variable is used by only manufacturer.)
0Y 0d	Total using time But if the product is used less than one minute from power-on to power-off, it is not added in total time.
FULL_OP	Full Open Time (Sec.) of valve
FULL_CL	Full Close Time (Sec.) of valve
VM NOR	Display type of valve stroke on LCD Either % or number is available.
Erro	Error or warning code currently occurred. Refer to the Code table.
VALUE I	Currently controlled I value (This variable is used by only manufacturer.)

Information checked on VIEW mode

Error and warning code

If there are any problems during YT-2400 operation, you can check the error and warning code at VIEW mode as follows.

Error code

This code is displayed when YT-2400 control gets impossible and code C, D is applied.

Warning code

This code is displayed when YT-2400 control is available but there's possibility of

malfunction or low accuracy. Code B, F, G, H is applied.

Code	Description and cause	Measures
A	None	None
B	The range of Pv Span - Pv Zero is less than 500. ⇒ Operating angle of feedback is too small.	⇒ Adjust operating angle of feedback lever to be bigger (Refer P.13) and execute AUTO 1 calibration.
C	More than 10% error is continued over than one minute. ⇒ There's no valve movement. ⇒ Valve friction is getting too big. ⇒ Setting pressure of regulator is changed.	⇒ Check the setting pressure of air filter regulator. Adjust it to recommending pressure. Execute BIAS calibration.
D	I value is at I max or min limit. ⇒ Valve friction is changed. ⇒ Setting pressure of regulator is changed.	⇒ Check the setting pressure of air filter regulator. Adjust it to recommending pressure. Execute BIAS calibration.
E	None	None
F	Full Open, Close time is less than one second. ⇒ Actuator size is too small.	⇒ Use variable orifice. ⇒ Replace actuator to bigger one.
G	Pv is set below than 100. ⇒ Operating angle of feedback lever is set too big.	⇒ Adjust operating angle of feedback lever to be smaller (Refer P.13) and execute AUTO 1 calibration.
H	Pv is over than 4000. ⇒ Operating angle of feedback lever is set too big.	⇒ Adjust operating angle of feedback lever to be smaller (Refer P.13) and execute AUTO 1 calibration.

Error/warning code

<http://www.ytc.kr>

Main software map

Firmware MAP

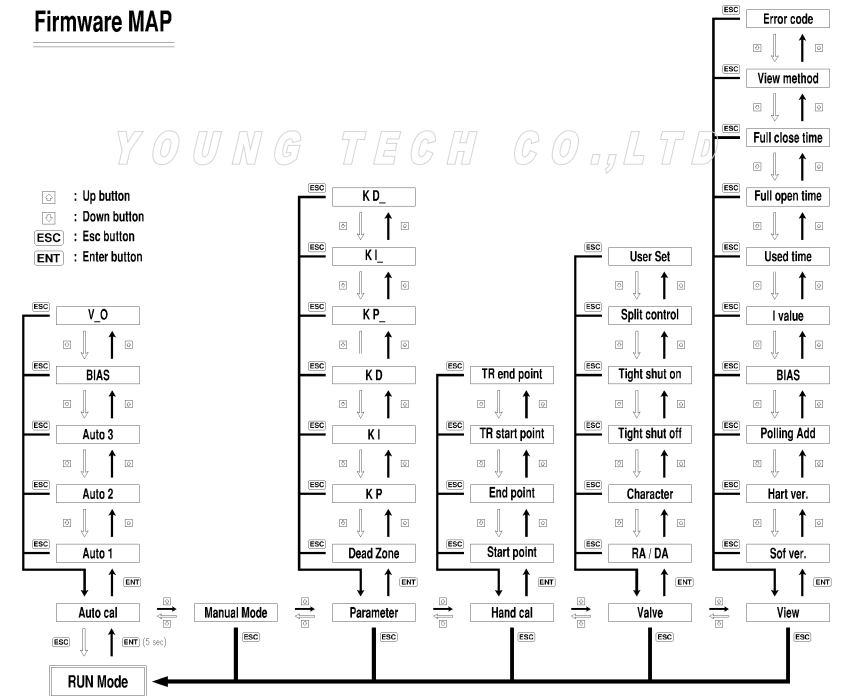

<http://www.ytc.kr>

Young Tech Co., Ltd

Address : #662-8 Pungmu-Dong, Gimpo-City, Kyunggi-Do, South Korea
Telephone: +82-31-986-8545
Fax: +82-31-986-2683
Website: <http://www.ytc.kr>

User Manual and other information on the documents are subjected to change without any notice.

Please visit website for most updated information.

Printed Date: Aug, 2008