



# Electro-pneumatic positioner



Doc: YT-2300R/02

Mar 2009

## YT2300R Intrinsically safe SMART Electro-Pneumatic positioner

### General:

The YT-2300 Series is a 'smart' positioner and controls valve movement accurately using a 4-20mA input signal. Using a highly efficient internal microprocessor it performs various and powerful functions such as auto-calibration, PID control, alarms, and HART protocol.

An LED display gives a continuous status indication and is used for many other functions.

### Hazardous area suitability:

This intrinsically safe positioner is ATEX II 2G/D approved for use in Zone 0 applications  Ex II 2 G/D EEx ia IIC T6

ATEX Certificate: TUV SUD ~ TPS 07 ATEX I 292 X

### Specifications:

Main air supply	1.4 ~ 7 bar, 20~100 psi
Control signal	4-20 mA DC
Impedance	Max 460 Ohm/ 20mA DC
Protection	IP 66
Linearity	± 0.5% Full Scale
Hysteresis	0.5% Full Scale
Sensitivity	± 0.2% Full Scale
Repeatability	± 0.3% Full Scale
Impedance	Max 460 Ohms / 20mA
Operating temp	-30 to +85C
Consumption	< 2LPM at 1.4 bar
Output Characteristics	Linear Equal percentage Quick opening User defined
Weight	1.5 kg



YT-2300 Aluminium



YT-2350 Stainless steel

### Features:

- An LCD screen makes it easy to inspect the state of the positioner in the field.
- Various types of information regarding the valve and positioner can be processed by using the optional Hart communication.
- Analogue feedback signal can be used to stabilise the valve.
- Various valve characteristics such as linear, quick open and equal percentage are available as options.
- PID parameters can be adjusted easily in the field by button.

### Applications:

The YT-2300 range is suitable for Zone 0 applications (EExia IIC T6).

It is strongly recommended that the supply air is filtered to 5 microns or better to protect the fine internal orifices within the YT-1000R. See our YT filter regulator data sheet(s) for details.

### Installation:

The YT-2300R is quick and simple to mount to a Namur compliant drive shaft, using the universal mounting bracket provided with the positioner.

Air connections are 1/4" NPT.

Gauge connections are 1/8" NPT

Conduit connection is G1/2"



# Electro-pneumatic positioner



Doc: YT-2300R/02

Mar 2009

## YT2300R Intrinsically safe SMART Electro-Pneumatic positioner

Positioner components:

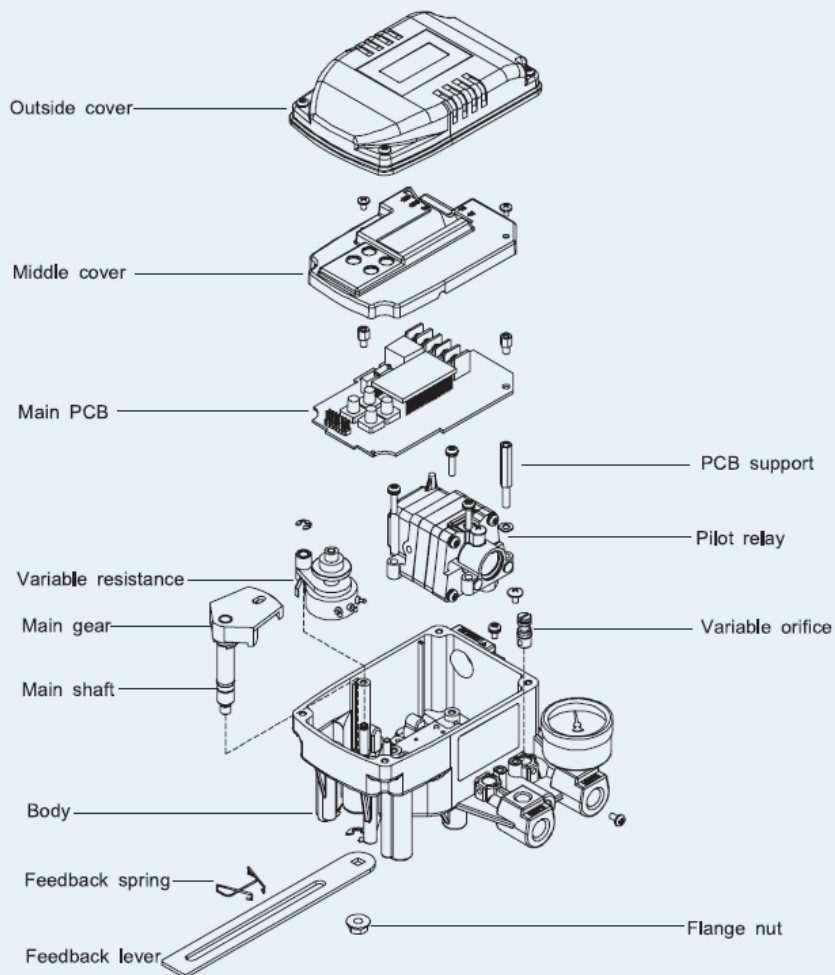

YT-2300 Structure



# Electro-pneumatic positioner



Doc: YT-2300R/02

Mar 2009

## YT2300R Intrinsically safe SMART Electro-Pneumatic positioner

### Features & functions:

1. LCD equipped outside of product makes to check the positioner condition in the field directly.
2. It endures severe vibration.
3. It is operated normally regardless of change of supply pressure during operation.
4. Auto calibration method is very simple.
5. It is easily equipped on small actuator because of its small size.
6. Air consumption is so small that operating cost in huge plants is decreased.
7. Because it can be used in low voltage (8.5V), there is no limitation in controller.
8. Variable orifice is applied and so in case of small actuator the hunting is controlled to the optimum condition during operation.
9. The adjustment of Valve characteristics (Linear, Quick open, Equal percentage) is available.
10. Specific flow control is available with setting 16 point at users' command.
11. Tight Shut-Close and Shut-Open can be set voluntarily.
12. PID parameters can easily adjusted in the field without additional communicator.
13. The pressure of Air filter regulator is sent to Actuator directly with using A/M switch.
14. Split range such as 4-12mA, 12-20mA is available.
15. Setting Zero and Span as partial section is available by Hand Calibration function.
16. The valve defect is easily checked because the valve can be operated voluntarily.
17. It has IP 66 protection grade.
18. Air filter regulator can be attached with the product with only one linear nipple without extra piping.
19. Because of Epoxy polyester powder coating, it can be used for long period of time in corrosive air.
20. Because of simple and modulized inner structure, maintenance is very easy.

### OPTION 1

Hart communication makes to process various information of valve and positioner.

### OPTION 2

Valve system is stable by outputting analog Feedback signal.

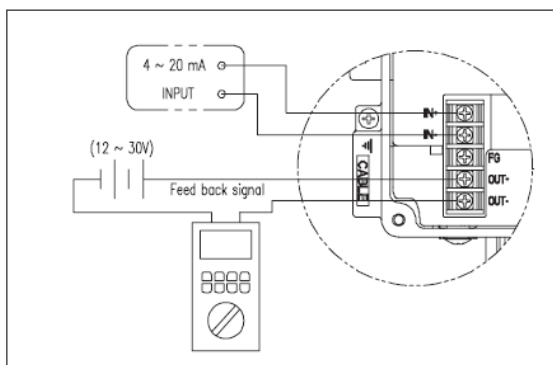



# Electro-pneumatic positioner



Doc: YT-2300R/02

Mar 2009

## YT2300R Intrinsicly safe SMART Electro-Pneumatic positioner

Features & functions: (continued)

### Linear, Quick open, EQ%

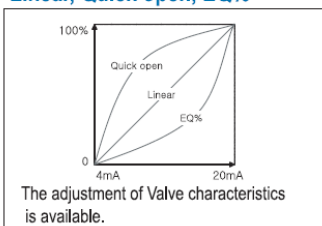

### User defined

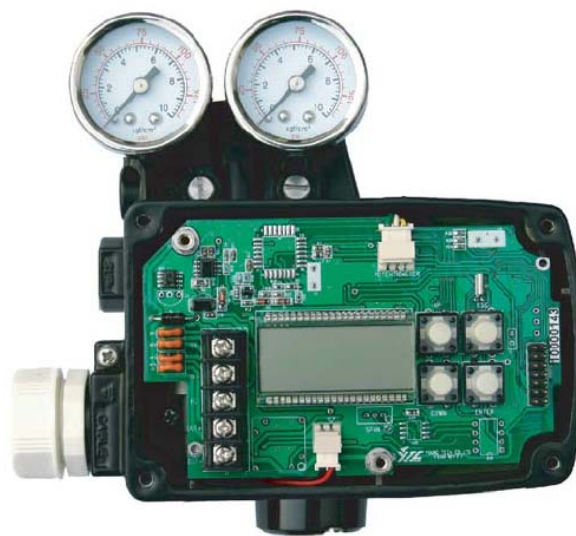
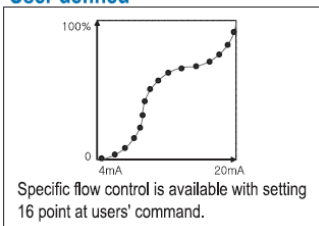

### Button

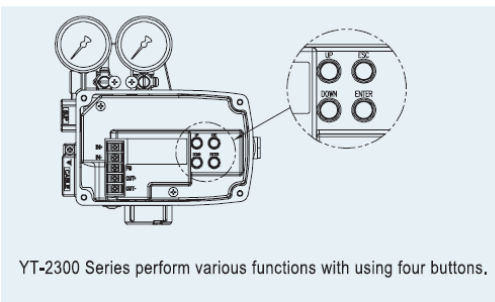

### LCD

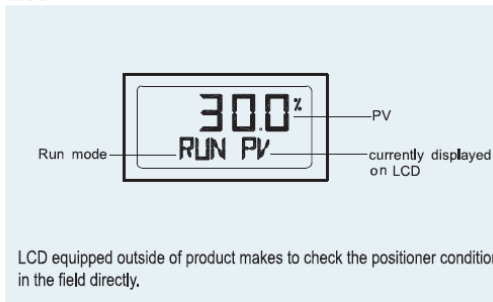

### A/M Switch

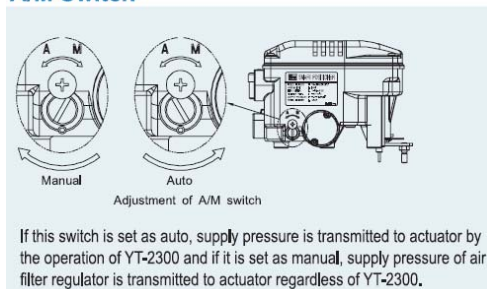

### Variable orifice

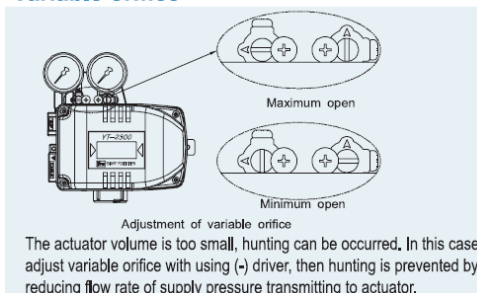



# Electro-pneumatic positioner



Doc: YT-2300R/02

Mar 2009

## YT2300R Intrinsically safe SMART Electro-Pneumatic positioner

### Auto calibration:

	Zero POINT	END POINT	KP,KI KD	BIAS	V_0	RA / DA
AUTO1	0	0	X	0	0	0
AUTO2	0	0	0	0	0	0
AUTO3	X	X	0	0	0	0
BIAS	X	X	X	0	X	X
V_0	X	X	X	X	0	X

Auto calibration types

AUTO1 calibration is useful for users in the field and AUTO2 calibration is for valve company or initial parameters setting of YT-2300.

It takes about 2-3 minutes for auto calibration and it can be different by actuator's volume. AUTO1, AUTO2 and AUTO3 calibration set RA/DA automatically.

### Software map:

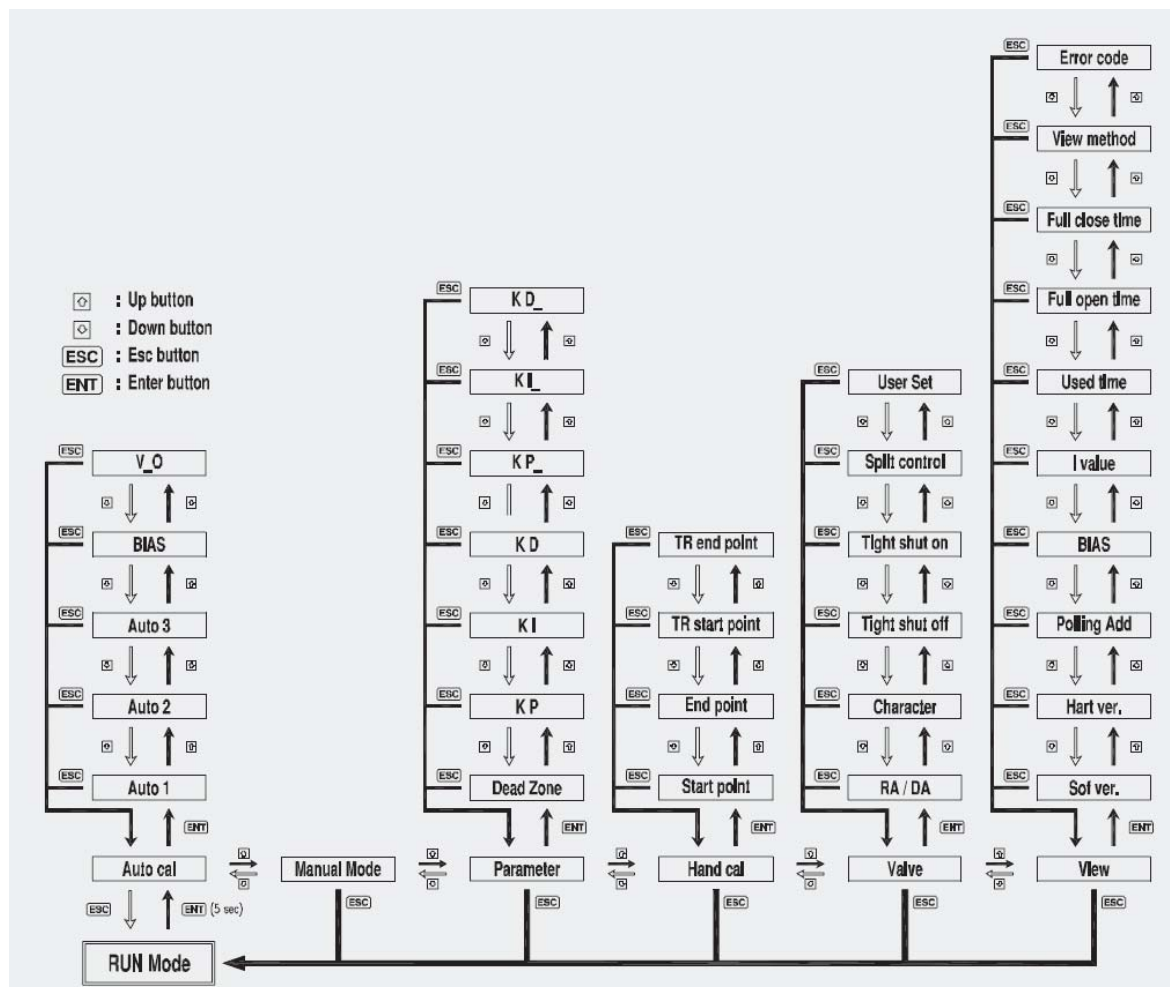



# Electro-pneumatic positioner



Doc: YT-2300R/02

Mar 2009

## YT2300R Intrinsically safe SMART Electro-Pneumatic positioner

YT-2300L drawing

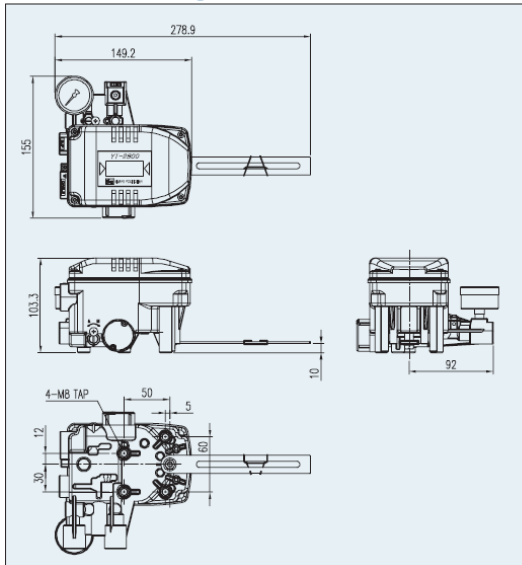

YT-2300R drawing

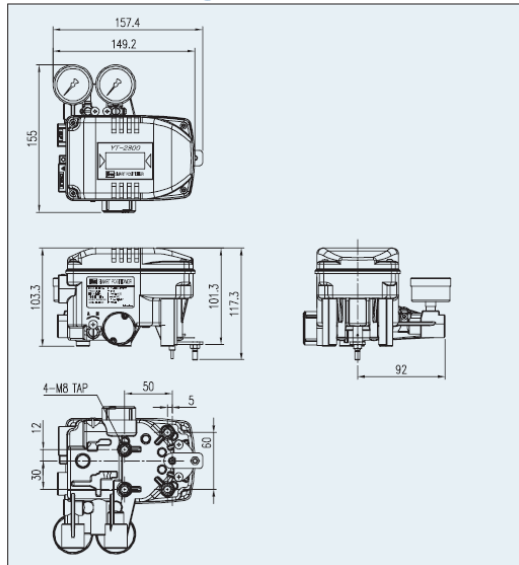

### Piping connection with actuator

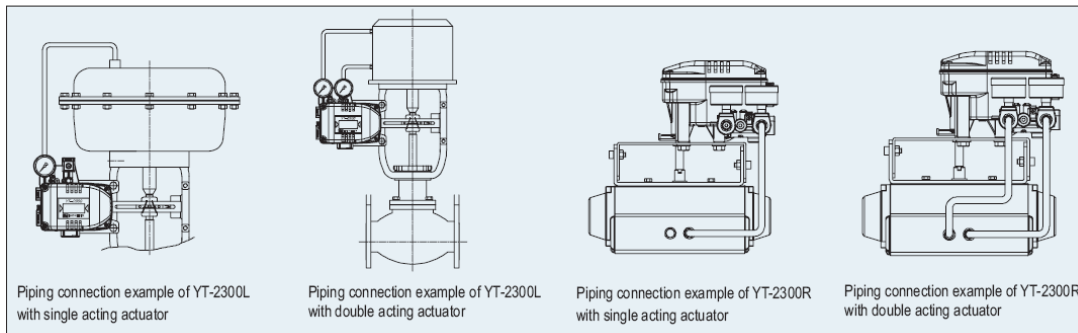

### YT-2300 Lever series

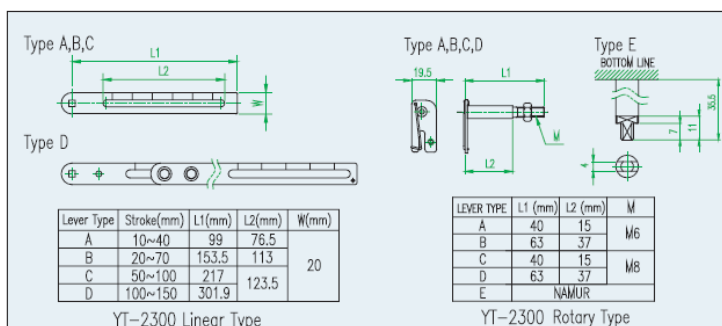

### YT-2300R Bracket

